

Vulcan[®]

Furnace

Service Manual

Models:

A-130
A550
A-1750

3-130
3-550
3-1750

3-550PD
3-550A
3-1750A

SAFETY

SAFETY FIRST

- Don't bypass the power cord's ground lead with two-wire extension cords or plug adaptors.
- Don't disconnect green/yellow safety-earth ground wire that connects the ground lug of the power receptacle to the chassis ground.
- Don't plug in the power cord until directed by the installation instructions.
- Don't repair the furnace unless you are a qualified technician and know how to work with hazardous voltages.
- Don't locate and operate the furnace in close proximity to combustible materials.
- Observe all WARNING statements. They point out situations that can cause injury or equipment damage.
- Disconnect the power cord before attempting to service.
- It is the user's responsibility to use only cleaning agents and materials that will not result in hazards to the equipment or material contained within.
- When replacing the main power supply cord use only a direct equivalent high-temperature cable.
- When replacing the main fuse use only a direct equivalent.

TABLE OF CONTENTS

SECTION 1

CIRCUIT DESCRIPTION		A-CONTROL
1.1	INTRODUCTION	1-1
1.2	CIRCUIT DESCRIPTION	1-1
1.2.1	Analog Meter Readout	1-1
1.2.2	Front Panel Controls	1-1
1.2.3	Muffle Control	1-1
1.2.4	Power Supply	1-1

SECTION 2

TROUBLESHOOTING		A-CONTROL
2.1	FACTORY REPAIR.....	2-1
2.2	BEFORE YOU START	2-1
2.3	TROUBLESHOOTING GUIDES	2-1
2.3.1	Power Supply	2-1
2.3.2	Analog Circuitry.....	2-1
2.3.3	Triac Drive.....	2-1
2.4	TROUBLESHOOTING COMPONENTS	2-1
2.5	BLOCK DIAGRAM.....	2-3
2.6	SCHEMATIC	2-4
2.7	CONTROL CIRCUIT BOARD.....	2-5
2.8	WIRING DIAGRAM	2-6

SECTION 3

CALIBRATION		A-CONTROL
3.1	SCOPE	3-1
3.2	FACTORY REPAIR.....	3-1
3.3	ADJUSTMENTS.....	3-1
3.3.1	Door, Lift Drag Adjustment	3-1
3.4	CIRCUIT BOARD CALIBRATION	3-1
3.4.1	Required Test Equipment	3-1
3.4.2	Temperature	3-1

SECTION 4

CIRCUIT DESCRIPTION		3-STAGE
4.1	INTRODUCTION	
4.2	CIRCUIT DESCRIPTION	4-1
4.2.1	LCD Display Readout.....	4-1
4.2.2	Front Panel Control	4-1
4.2.3	Muffle Control.....	4-1
4.2.4	Power Supply.....	4-1
4.2.5	Motor Drive Control.....	4-1
4.2.6	Fan Drive Control	4-1

SECTION 5

TROUBLESHOOTING		3-STAGE
5.1	FACTORY REPAIR.....	5-1
5.2	BEFORE YOU START	5-1
5.2.1	Isolating a Problem	5-1
5.3	TROUBLESHOOTING GUIDES	5-1
5.3.1	Power Supply	5-1
5.3.2	Microprocessor	5-1

5.3.3	Peripheral Drive	5-1
5.3.4	Motor Drive	5-1
5.3.5	Analog Circuitry.....	5-1
5.3.6	Display Board	5-1
5.3.7	Fan Drive Control	5-2
5.4	TROUBLESHOOTING COMPONENTS.....	5-2
5.5	ERROR CODES.....	5-3
5.6	DIAGNOSTIC TABLES	5-4
5.7	BLOCK DIAGRAM.....	5-8
5.8	SCHEMATICS	5-9
5.9	WIRING DIAGRAM	5-12

SECTION 6

ADJUSTMENT/CALIBRATION3-STAGE		
6.1	SCOPE	6-1
6.2	FACTORY REPAIR	6-1
6.3	ADJUSTMENT/CALIBRATION	6-1
6.3.1	Temperature	6-1
6.3.2	Door, Lift Drag Adjustment	6-1
6.4	CIRCUIT BOARD CALIBRATION	6-1
6.4.1	Required Test Equipment	6-1
6.4.2	Temperature	6-1

SECTION 7

SERVICE PARTS		
7.1	ORDERING INSTRUCTIONS.....	7-1
7.2	MUFFLE AND THERMOCOUPLE	7-1
7.3	MUFFLE (3-550 PD / AIR EXCH).....	7-2
7.4	CABINET PARTS.....	7-3
7.5	DOOR PARTS	7-4
7.6	A-CONTROLLER PARTS	7-5
7.7	3-STAGE & 3-550 CONTROLLER PARTS.....	7-6
7.8	LIFT MECHANISM PARTS (3-550PD)	7-7

SECTION 8

DISASSEMBLY/REASSEMBLY		
8.1	CONTROL DRAWER REMOVAL.....	8-1
8.2	TRIAC.....	8-1
8.3	MEMBRANE SWITCH.....	8-2
8.4	DISPLAY PCB	8-3
8.5	A-CONTROL PCB	8-4
8.6	3 STAGE CONTROL PCB	8-5
8.7	DOOR ASSEMBLY/ADJUSTMENT	8-6
8.8	HEATING PLATES.....	8-7
8.9	MUFFLE REPLACEMENT.....	8-8
8.10	THERMOCOUPLE (A-Control)	8-9
8.11	THERMOCOUPLE (3 STAGE)	8-9
8.12	MUFFLE REPLACEMENT(3-550 PD).....	8-10
8.13	THERMOCOUPLE (3-550PD)	8-11
8.14	POWER SWITCH.....	8-12
8.15	POWER DOOR REPLACEMENT	8-13

SECTION 1 - CIRCUIT DESCRIPTION - A-CONTROL

1.1 INTRODUCTION

The purpose of this section is to familiarize the user or service personnel with the circuit level operation of the VULCAN. This knowledge is necessary to aid in troubleshooting of a unit's failure and may also allow the user to gain greater insight into the VULCAN's versatility for particular applications. A detailed description is given for the following circuit functions:

- Analog Meter Readout
- Front Panel Controls
- Muffle Control
- Power Supply

1.2 CIRCUIT DESCRIPTION

1.2.1 ANALOG METER READOUT

The Type K thermocouple which extends from the back of the muffle is directly connected to an analog meter which provides the operator with the present muffle temperature. The yellow lead of the thermocouple is connected to the + input of the meter.

1.2.2 FRONT PANEL CONTROLS

The power on/off switch provides AC line voltage to the furnace if the door switch is closed, while the setpoint potentiometer (10K) provides the electronics with a reference voltage which determines the final muffle temperature.

1.2.3 MUFFLE CONTROL

The muffle is controlled by means of a triac. This muffle triac may be activated anytime when the AC cycle goes through zero, and once activated it will only be opened again when the AC sine wave passes through 0 volts. The triac is controlled by a Zero Voltage Switch (integrated circuit U2) and is configured as a proportional controller. Trigger pulses are generated when the comparator detects Vpin3 is above the Vref. The sensed temperature from the amplified thermocouple signal is then lower than the set value of RP2. As Vpin3 is near in value of Vref, a proportional control takes over, i. e. power is delivered by bursts to the load.

To slow down the heatup time of the muffle (RP2 set clockwise and muffle is at low temperature) a rate control potentiometer (RP3) has been added to the circuitry. A sawtooth signal from pin2 of U2 is compared with a fixed reference voltage which can be set by RP3. As the sawtooth voltage exceeds the value of the fixed reference voltage, amplifier U3 produces a negative output which in turn increases the thermocouple signal output from U1 and Vpin3 of U2 and is now more negative than Vref, thus the triac output pulses stop.

1.2.4 POWER SUPPLY

The rectified supply current (D2) is zener regulated to 8.6V and biased by dropping resistors R11, R12. The positive voltage to U1 and U2 is provided by a 6.8V zener diode D1.

NOTES:

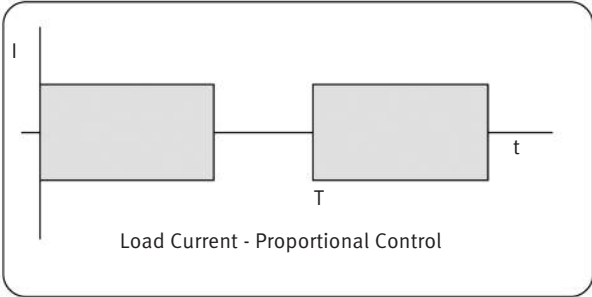

SECTION 2 - TROUBLESHOOTING - A-CONTROL

2.1 FACTORY REPAIR

DENTSPLY Ceramco maintains a factory repair department for those customers not possessing the necessary personnel or test equipment to maintain the VULCAN. If a unit is returned to the factory for calibration or repair, a detailed description of the specific problem should be attached to minimize turnaround time. Call factory for PR number before shipping at 1-800-835-6639.

2.2 BEFORE YOU START

Since no troubleshooting guide can possibly cover all the potential problems, the aim of this guide is to give a methodology which, if applied consistently, will lead to the problem area. Therefore, it is necessary to familiarize yourself with the VULCAN by reviewing the functional description in conjunction with the schematic. Successful troubleshooting depends upon understanding the circuit operation.

WARNING:

With covers removed, dangerous voltage points may be exposed. Contact with any of these points could cause serious injury.

2.3 TROUBLESHOOTING GUIDES

WARNING:

When measuring voltages use battery operated test equipment unless an isolation transformer is connected between circuit input and AC line.

2.3.1 POWER SUPPLY

Rectifier diodes D2 and D3 convert the AC line voltage to a DC voltage, while resistors R11, R12 reduce the current flow thru the 8.6V internal zener diode of U2 and the 6.8V external zener diode D1. Capacitors C1 and C5 filter the rectified voltages. Most of the circuit's current consumption is taken up by the triac gate drive.

2.3.2 ANALOG CIRCUITRY

The thermocouple voltage which ranges from 0-45mV (25°C - 1100°C) is multiplied by amplifier U1 approximately 100 times (depending on the setting of potentiometer RP1) and added to the negative setpoint voltage from RP2. A sawtooth voltage signal is generated by U2 from a constant current source charging capacitor C4. The value of C4 determines the burst period of the triac output (typically 8 seconds). The triac gate output pulse current is about 60mA. The triac is triggered in quadrants II and III. Synchronization is provided by resistor R10. Its value determines the trigger pulse length.

2.3.3 TRIAC DRIVE

A current pulse from U2 pin 6 of about 60mA will turn on the gate of the muffle triac which in turn will then carry the full load current. The voltage across the triac is now at 1-2 Vac. In order to comply with norms limiting the frequency at which a kW size load may be connected to the main line (fluorescent tubes "flickering") a proportional temperature control is provided by means of burst firing the triac.

NOTES:

2.4 TROUBLESHOOTING COMPONENTS

2.4.1 DIODE

A diode (except a zener) is defective if there is greater than 1 Vdc (typically 0.7 Vdc) forward voltage across it.

2.4.2 OPERATIONAL AMPLIFIER

Generally, the "+" and "-" inputs of an operational amplifier will have less than 15 mV voltage difference when operating under normal conditions. If the output voltage stays at maximum positive (typically 1/3 of the supply voltage), the "+" input voltage should be more positive than the "-" input voltage. If the output voltage stays at minimum (typically 1-5 mV), the "-" input voltage should be more positive than the "+" input voltage.

2.4.3 TRIAC

The gate to power line return voltage under load measures typically 1-2 Vac, while the MT2 to return voltage measures between 1.3-1.8 Vac. A triac without connections and no power applied can be checked for a go-no go condition with an ohmmeter. The gate to MT1 resistance for a power triac (20-40A) should be between 50 and 100 ohms; there should be infinite resistance between MT1 and MT2.

2.4.4 CAPACITOR

Shorted capacitors have 0V across their terminals. Open capacitors can be located by using a good capacitor connected in parallel with the capacitor under test and observing the resulting effect.

SECTION 2 - TROUBLESHOOTING - A-CONTROL

Leaking capacitors will often have a decreased voltage across their terminals.

NOTES:

SECTION 2 - TROUBLESHOOTING - A-CONTROL

2.5 BLOCK DIAGRAM

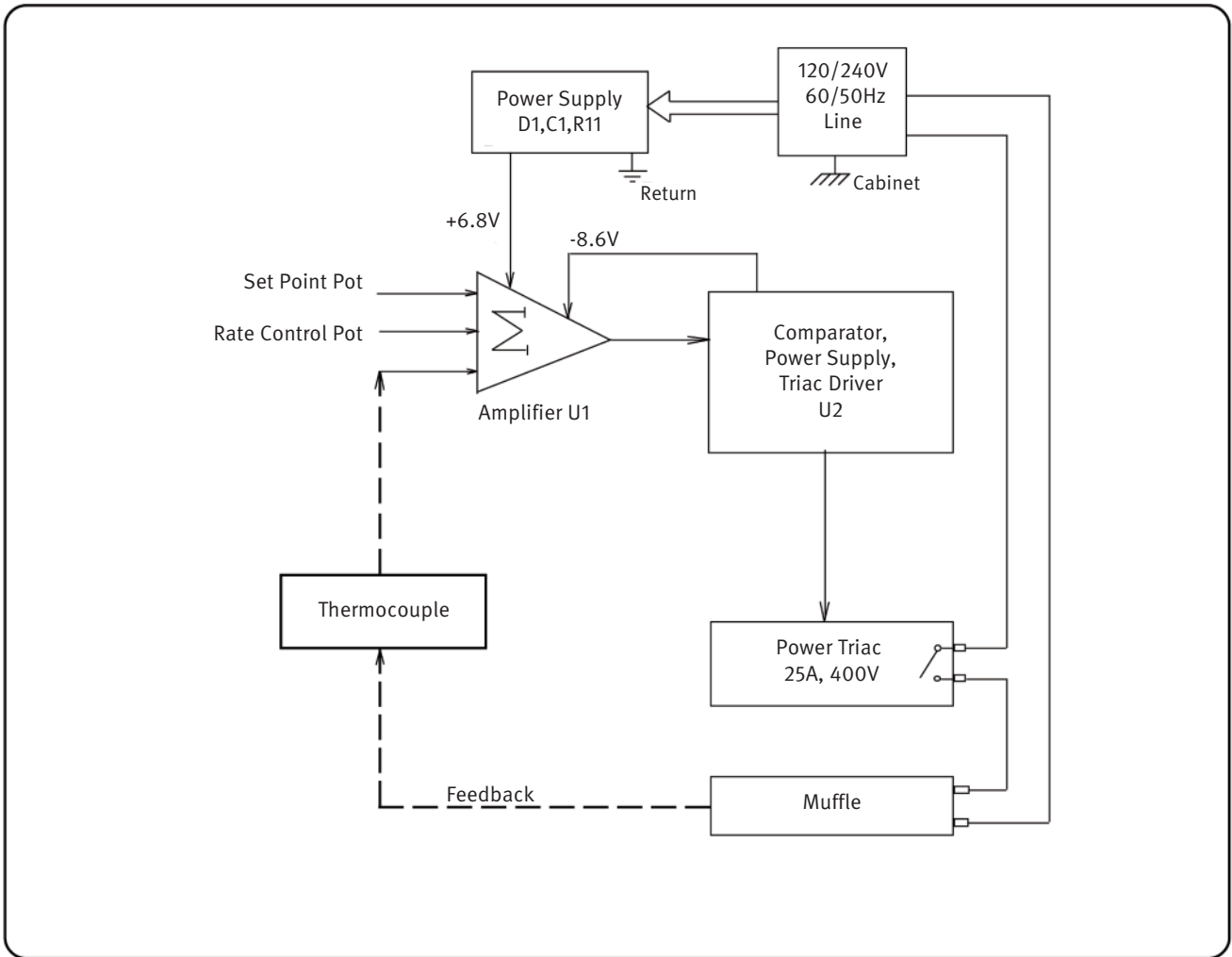

SECTION 2 - TROUBLESHOOTING - A-CONTROL

2.6 SCHEMATIC

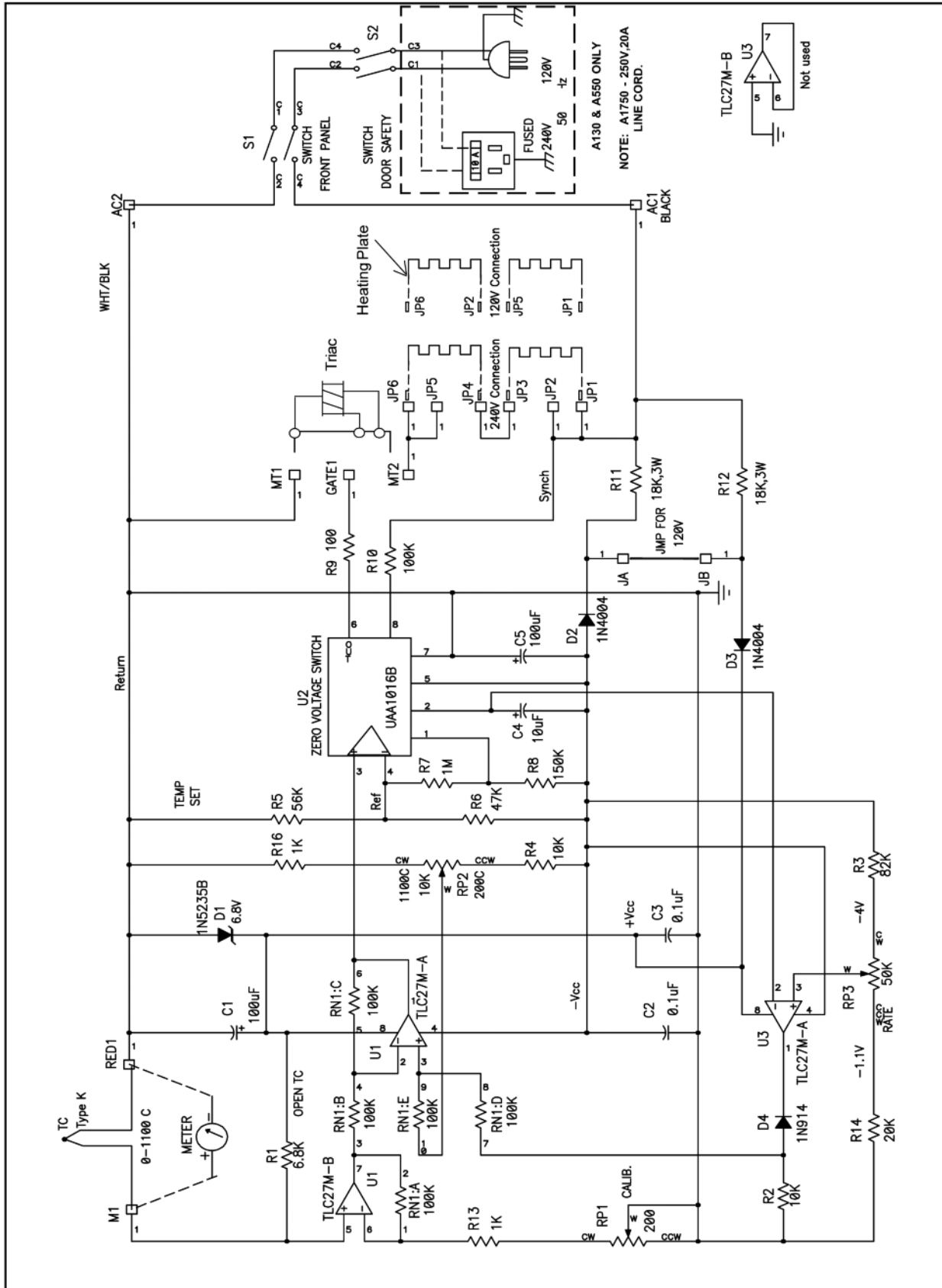

SECTION 2 - TROUBLESHOOTING - A-CONTROL

2.7 CONTROL CIRCUIT BOARD

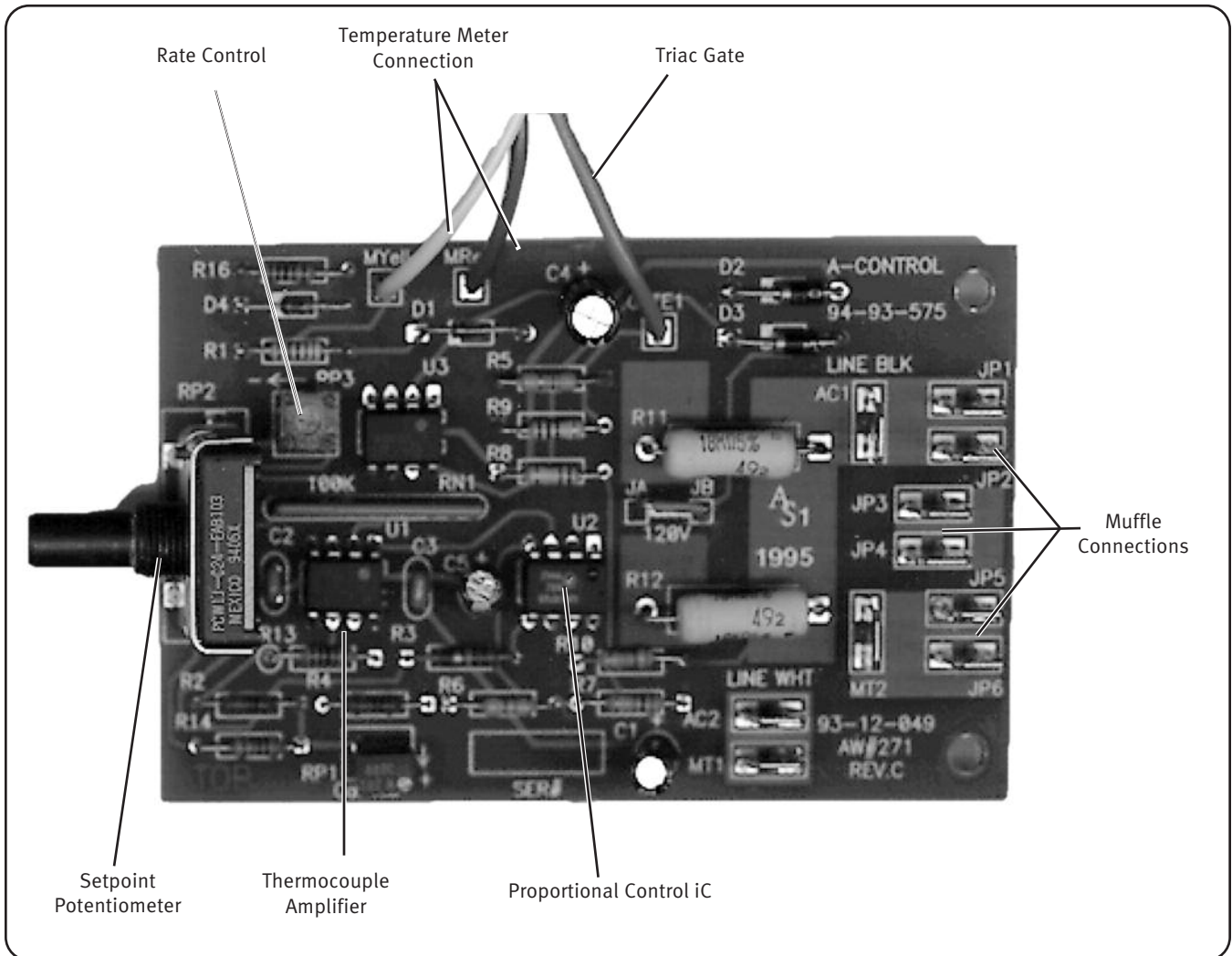

SECTION 2 - TROUBLESHOOTING - A-CONTROL

2.8 WIRING DIAGRAM

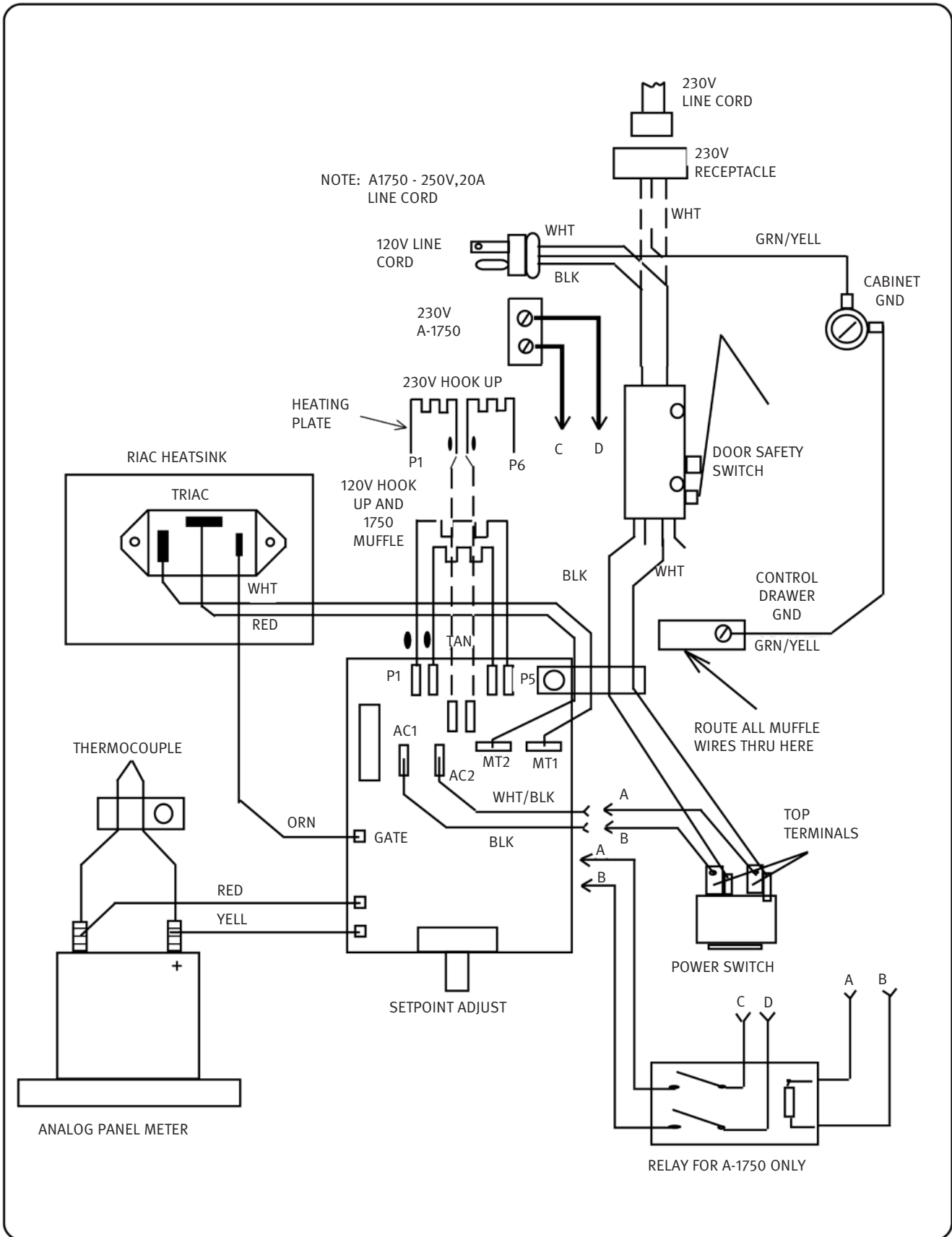

SECTION 3 - ADJUSTMENT/CALIBRATION - A-CONTROL

3.1 SCOPE

This section gives the procedures to be used for the calibration and specification verification of the VULCAN. The furnace specifications are given in the Owner & Operator's Manual.

3.2 FACTORY REPAIR

DENTSPLY Ceramco maintains a factory repair department for those customers not possessing the necessary personnel or test equipment to maintain the VULCAN. If a unit is returned to the factory for calibration or repair, a detailed description of the specific problem should be included to minimize turnaround time. Call factory for RMA number before shipping at 909-.795.2461.

3.3 ADJUSTMENTS

3.3.1 DOOR, LIFT DRAG ADJUSTMENT

The lift drag force is controlled by a set of friction washers on each of the upper pivot arms. If the drag becomes too stiff (too hard to open and close furnace) or too loose an adjustment can be made using the following procedure:

TOOLS: 5/32" Allen Wrench

- Turn the allen head screws on the upper side of the furnace either clockwise to tighten or counterclockwise to loosen the drag force.

NOTE:

Equal adjustment should be made on each side. Turn screws only 1/6 of a revolution at a time when making adjustment.

Connect DMM to PCB as shown in Figure 7-2:

- For all 120V Units: Adjust RP# to read 19K-20K Ohms
- For all 220V-240V Units: Adjust RP3 Fully Clockwise (CW)



Black Lead to U3 Pin 3 Here Front of Control Drawer Red Lead to R14 Here

Figure 7-2

3.4 CIRCUIT BOARD CALIBRATION

Calibration of the VULCAN circuit board is performed in one single step.

3.4.1 REQUIRED TEST EQUIPMENT

- Multimeter
- Pot adjustment tool

WARNING

With control drawer opened, dangerous voltage points may be exposed. Contact with any of these points could cause serious injury.

3.4.2 TEMPERATURE

Disconnect the power cord from the wall outlet and open the control drawer. Connect the black lead of the ohmmeter to the red thermocouple connection on temperature meter. Touch the red lead of the ohmmeter to the leg with a circle on R13. Adjust RP1 to read 1060 ohms on the ohmmeter.

On models A-550 rated at 120V the potentiometer RP3 should be adjusted the following way:

Touch the black lead of the ohmmeter to pin 3 of U3 and the red lead to the leg of R14, see figure 7.2. Adjust RP3 to read between 19 and 20 Kohm on the ohmmeter. This adjustment limits the amount of current going thru the muffle by about 15% in order to comply with safety agency rulings. For all other models RP3 should be fully clockwise.

As an alternate circuit board calibration, without the use of an ohmmeter, bring the furnace temperature to the desired level. At steady state temperature insert a thermocouple, connected to a temperature monitor, into the exhaust opening of the furnace and after stabilization read the muffle temperature. Compare this reading with the temperature meter reading of the furnace. In several steps adjust RP1 to obtain equal readings. Allow ample time between adjustment steps since only a few watts are added/subtracted which each adjustment of RP1.

SECTION 4 - CIRCUIT DESCRIPTION - 3-STAGE

4.1 INTRODUCTION

The purpose of this section is to familiarize the user or service personnel with the circuit level operation of the VULCAN. This knowledge is necessary to aid in troubleshooting of a unit's failure and may also allow the user to gain greater insight into the VULCAN's versatility for particular applications. A detailed description is given for the following circuit functions:

- * Display Readout
- * Front Panel Control
- * Muffle Control
- * Power Supply
- * Motor Drive Control (option for 3-Stage)
- * Temperature Measurement

The muffle temperature is derived from a Thermocouple (type "K") which generates an output voltage of up to 50mV. This feedback signal is then manipulated by the electronics to control the muffle temperature.

4.2 CIRCUIT DESCRIPTION 3-STAGE

4.2.1 LCD DISPLAY READOUT

The display board converts serial data from the microprocessor to 8-bit parallel data. Each byte transferred is either a command or a data byte depending on the state of the two control bits RS and E (DIS ENA). The 16 character LCD module is controlled by the microprocessor via its Serial Peripheral Interface (SPI) port. The display is updated every 0.5 sec or when a corresponding front panel key has been activated.

4.2.2 FRONT PANEL CONTROL

The power on/off switch switches the AC line voltage. The membrane switches are arranged in a 8x4 matrix. The microprocessor scans the entire matrix every 50 msec by setting one column at a time to a logic 0 and then reading the rows. Once a contact closure has been detected this value is stored.

4.2.3 MUFFLE CONTROL

The microprocessor (U9) sends a serial digital signal to an octal peripheral driver (U6) which in turn converts and latches it to parallel data. This data is then used to drive several peripheral devices. U9 is connected to an opto isolator (U7). The isolator's output is connected to the gate of the muffle triac. The muffle triac may be activated anytime during an AC cycle, but once activated it can only be opened when the AC sine wave passes through 0 volts. U9 accesses U7 0.5 msec before zero crossing to turn the triac off. At this time a value calculated by the control routine determines how much time should elapse before the triac is turned on again.

4.2.4 POWER SUPPLY

One DC power supply voltage is generated on the control circuit board +5V.

4.2.4.1 +12V SUPPLY

The +12 VDC is generated from 15 watt switching power supply mounted onto the main control PC board.

4.2.4.2 +5V SUPPLY

Refer to schematic, page 5-9. DC voltage from the output of the switching power supply is used by the +5V linear regulator U3 to generate the +5V. The capacitor C21 provides additional filtering. The 1.23V reference diode D1 generate their outputs from this supply.

4.2.5 MOTOR DRIVE CONTROL (3-550 PD)

The +12VDC motor which moves the door vertically is controlled by a 16 pin motor controller/driver I.C. This I.C. provides all necessary functions for a complete closed loop system. A two wire cable connects the motor to the 1 Amp H-bridge switch on the I.C. The microprocessor (U9) activates the H-switch through two input pins. If both are low the motor will turn in one direction, if both are high the motor turns in the opposite direction. A third pin sends a signal from the motor controller/driver I.C. to the microprocessor when the motor has stalled (up or down position).

4.2.6 FAN DRIVE CONTROL 3-550A/1750A

The air exchange fan is controlled by means of the front panel membrane switch. Speed selections are from 0 - 9 (0 is off and 9 is highest speed). Speed 1 selection changes the air in the muffle twice a minute.

NOTES:

SECTION 5 - TROUBLESHOOTING - 3-STAGE

5.1 FACTORY REPAIR

DENTSPLY Ceramco maintains a factory repair department for those customers not possessing the necessary personnel or test equipment to maintain the VULCAN. If a unit is returned to the factory for calibration or repair, a detailed description of the specific problem should be attached to minimize turnaround time. Call factory for PR number before shipping at 1-800-835-6639.

5.2 BEFORE YOU START

Since no troubleshooting guide can possibly cover all the potential problems, the aim of this guide is to give a methodology which, if applied consistently, will lead to the problem area. Therefore, it is necessary to familiarize yourself with the VULCAN by reviewing the functional description and the detailed circuit description (Section 4) in conjunction with the schematics (Section 5). Successful troubleshooting depends upon understanding the circuit operation within each functional block as well as the block relationships.

WARNING

With covers removed, dangerous voltage points may be exposed. Contact with any of these points could cause serious injury.

The intent of this section is to provide the information to return the VULCAN to proper operation. Information is divided into two parts. Part one contains the overall furnace troubleshooting block diagram which is useful in isolating defective blocks within the furnace. Part two consists of a series of circuit guides, one for each block shown in the block diagram, that provides settings and measurements for troubleshooting an individual block. Also, each circuit guide references related schematics and circuit descriptions. Inspect the components, wiring and circuit boards of the VULCAN for damage. Finally, ensure that the fuses are intact and the internal power supplies are good.

5.2.1 ISOLATING A PROBLEM

To successfully troubleshoot this furnace, the symptoms must first be identified, the faulty block isolated, then analyzed, and finally the defective component located and replaced.

After the block is isolated, refer to the appropriate functional circuit guide.

The circuit guide provides some but not necessarily all of the possible failure modes for a particular circuit. Where applicable, a furnace setup procedure is given to help isolate the problem for a particular failure mode.

5.3 TROUBLESHOOTING GUIDES

5.3.1 POWER SUPPLY

To determine a faulty power supply use the table on page 5-3. To troubleshoot a faulty power supply use the procedures listed on page 5-4. If the desired results are obtained in each of the steps in the tables, replace D43, U9 or U7 as appropriate.

5.3.2 MICROPROCESSOR

Generally, when the furnace is totally nonfunctional, i.e., display is unintelligible, no display, random relay clicking, no key response, or the front panel LED's stay on at power up, the problem is in the microprocessor section. However, before troubleshooting this section, check the appropriate dedicated circuits for correct operation. Detailed reading of the circuit description is also very important. See page 5-5 to troubleshoot the microprocessor.

5.3.3 PERIPHERAL DRIVE

The peripheral driver U6 is accessed at every line voltage zero crossing by the microprocessor. The logic state of the eight output drivers, Y0 -Y7, is latched into the shift register at time t0 on the high to low transition of SIOE. Input data present at the SI input is clocked into the shift register on the high to low transition of SCLK. See page 5-6 to troubleshoot the peripheral driver.

5.3.4 MOTOR DRIVE (OPTIONAL ACCESSORY)

The motor driver U8 is accessed by the microprocessor to lift or lower the door. U8 provides a feedback to the microprocessor to indicate an overcurrent condition which is set at approximately 1.00Amp by resistor R3. See page 5-6 to troubleshoot the motor driver.

5.3.5 ANALOG CIRCUITRY

The reference voltages used to control temperature and compare voltage signals are derived from the output of U1-7 (+5V) and D1. See schematics for troubleshooting individual components. See page 5-6 to troubleshoot the analog circuitry.

5.3.6 DISPLAY BOARD

Serial data present on the input of U1-14 and U2-2 is transferred to the shift register on the logic "0" to logic "1" transition of the Clock input pulse. Information present at any register of U1 is transferred to its respective latch when the Strobe is high (U1-7). A serial to parallel conversion takes place. As long as the Strobe is held high ("1") the latches will accept new data. The LCD display module will accept valid data on D0 - D7 when the Enable (J1-6) goes from a high to low transition. See page 5-7 to troubleshoot the display circuit board.

SECTION 5 - TROUBLESHOOTING - 3-STAGE

5.3.7 FAN DRIVE (OPTIONAL ACCESSORY)

The 12V DC fan is controlled by a FET device which is activated by the microprocessor. At its highest setting (9), the fan receives the full 12V DC. At lower settings the fan receives +12V pulses, to reduce the rpm's.

5.4 TROUBLESHOOTING COMPONENTS

5.4.1 DIODE

A diode (except a zener) is defective if there is greater than 1 Vdc (typically 0.7 Vdc) forward voltage across it.

5.4.2 OPERATIONAL AMPLIFIER

Generally the "+" and "-" inputs of an operational amplifier will have less than 15 mV voltage difference when operating under normal conditions. (U1). When the output of the amplifier is connected to the "-" input (voltage follower connection), the output should be the same voltage as the "+" input voltage; otherwise, the amplifier is defective.

If the output voltage stays at maximum positive (typically 1/3 of the supply voltage), the "+" input voltage should be more positive than the "-" input voltage.

5.4.3 TRIAC

The gate to power line return voltage (K1) under load measures typically 1-2 Vac, while the MT2 to return voltage measures between 1.3-1.8 Vac.

A triac without connections can be checked for a go-no go condition with an ohmmeter. The gate to MT1 resistance for a power triac (20-40A) should be between 50 and 100 ohms; there should be infinite resistance between MT1 and MT2.

5.4.4 CAPACITOR

Shorted capacitors have 0V across their terminals. Open capacitors can be located by using a good capacitor connected in parallel with the capacitor under test and observing the resulting effect. Leaking capacitors will often have a decreased voltage across their terminals.

5.4.5 LOGIC LEVELS

Microprocessor:	High	+3.5	-	+5.0V
	Low	0.0	-	+1.0V
74LSXXX:	High	+2.0	-	+5.0V
	Low	0.0	-	+0.5V
4XXX (CMOS):	High	+3.5	-	+5.0V
	Low	0.0	-	+1.5V

SECTION 5 - TROUBLESHOOTING - 3-STAGE

5.5 ERROR CODES

ERR 1 MUFFLE OVER TEMPERATURE

The controller monitored a temperature above °C. This could mean a faulty thermocouple (mV reading too high) or an erratic thermocouple performance (the temperature readout is not stable at elevated temperatures).

ERR 2 OPEN TC DETECTED

To check for open TC, turn power to furnace off and short TC input terminals. Turn power back on. If ERR 2 disappears, then replace TC.

Possible solutions:

Change PCB if problem persists.

ERR 3 TMAX OVER TEMP

The controller monitored a temperature above Tmax + 20°C. This could mean:

- * The Tmax was set up too low for this program
- * The destination temperature is relatively low compared to the programmed heat rate, eg. too much temperature overshoot.

ERR 8 EEPROM READ/WRITE ERROR (APPLIES TO 9493980 ONLY)

Program parameters entered during the idle mode are transferred and stored in a 16K-bit Electrically Erasable Programmable Read Only Memory (EEPROM) device. The serial data on U10 is monitored and any abnormal behavior from the devices' specs is answered with an error code. Press ENTER and check:

- * Data, Clock train on U10-5,6
- * Replace device

ERR 19 NO LINE FREQUENCY DETECTED (APPLIES TO 9493980 ONLY)

- * Check U1 A-1, 100 or 120 Hz pulse train
- * Remove Power

SECTION 5 - TROUBLESHOOTING - 3-STAGE**5.6 DIAGNOSTIC TABLES****FURNACE SETUP COMMON ERRORS**

Symptom	Possible Setup Error
Display blank	No line voltage Power switch failure J8 disconnected
No Setup functions after ENTER	Furnace was in start cycle at power down
Muffle does not heat after power up	Not in start cycle Door switch not closed
No door movement after switch is pressed	Furnace is in TEST mode Motor connector J5 loose

POWER SUPPLY VOLTAGES

Output Voltage	Voltage Tolerance	Output Ripple	Test At	Input Ripple	Test At
+12V	+/-350mV	0.02Vac	PT1 & PT4	3Vac	PT1 & PT4
+ 5V*	+/-250mV	0.02Vac	U3-3	3Vac	U3-1

* Note: +5VDC is dependent on the presents of the 12VDC, U3 on the main PC Board regulates the +5VDC.

SECTION 5 - TROUBLESHOOTING - 3-STAGE**5.6 DIAGNOSTIC TABLES****POWER SUPPLY**

Fault	Setup	Check	Results desired
No DC output and no DC to U11-2 (15-30V) PT1 to PT4	Power off	Fuse	< 1 ohm Not shorted or open Not shorted or open

MICROPROCESSOR

Fault	Setup	Check	Results desired
Nonfunctional operation	N/A	U9-3, 2 X1 U9-26 U9-9 U9-10	4.9MHz, sinusoid approximately 0-4V >4.5V waveform +5VDC
	Power Off/On	Listen	Relay clicks, Sonar

SECTION 5 - TROUBLESHOOTING - 3-STAGE

5.6 DIAGNOSTIC TABLES

PERIPHERAL DRIVE CIRCUIT

Fault	Setup	Check	Results desired
All Y outputs high	N/A Turn furnace Off then On Turn furnace Off	U6-1, 2, 6 Display/ LED's D2, D3, D4, D6	No stuck bits No Error codes Display OK Not shorted or open

MOTOR DRIVE CIRCUIT

Fault	Setup	Check	Results desired
No door up or down when switch is activated	Furnace in idle Disconnect J5 Turn furnace on Activate switch Activate switch Turn furnace off Turn furnace on	U8-16 U8-10-15 U13-15 Motor switch	+12 VDC digital high Other keys respond
At up or down position	Add mA meter in series at J5	Stall current	> 550 mA at up or down

SECTION 5 - TROUBLESHOOTING - 3-STAGE

5.6 DIAGNOSTIC TABLES

ANALOG CIRCUITRY

Fault	Setup	Check	Results desired
Muffle heats but display shows same temperature	N/A	YELL2 U4 D1	TC yellow connected Gain approx. 20 1.23V
Erratic temperature display	N/A	D1 U4-11 & 12	1.23V stable DC stable
Temperature drift	Hi T = 960°C Turn furnace off	RED U4-13 Reconnect TC wires	39-40mV stable mV stable (.2mV/°C ambient increase typical) No Err2 at elevated temperatures

DISPLAY BOARD

Fault	Setup	Check	Results desired
LCD dots are all on or off at power up	Furnace in idle	J8-1 J4-8	+5V Tight fit
No LED's light up	Perform power up N/A	Front Panel J8-4	LED's turn off one by one +12V
One LED does not come on	Turn furnace off	LED	Not open or shorted
LCD display is darker	Turn furnace off Turn furnace on	Temperature on panel Temperature on panel	Less than 40°C LCD lighter shade

SECTION 5 - TROUBLESHOOTING - 3-STAGE

5.7 BLOCK DIAGRAM

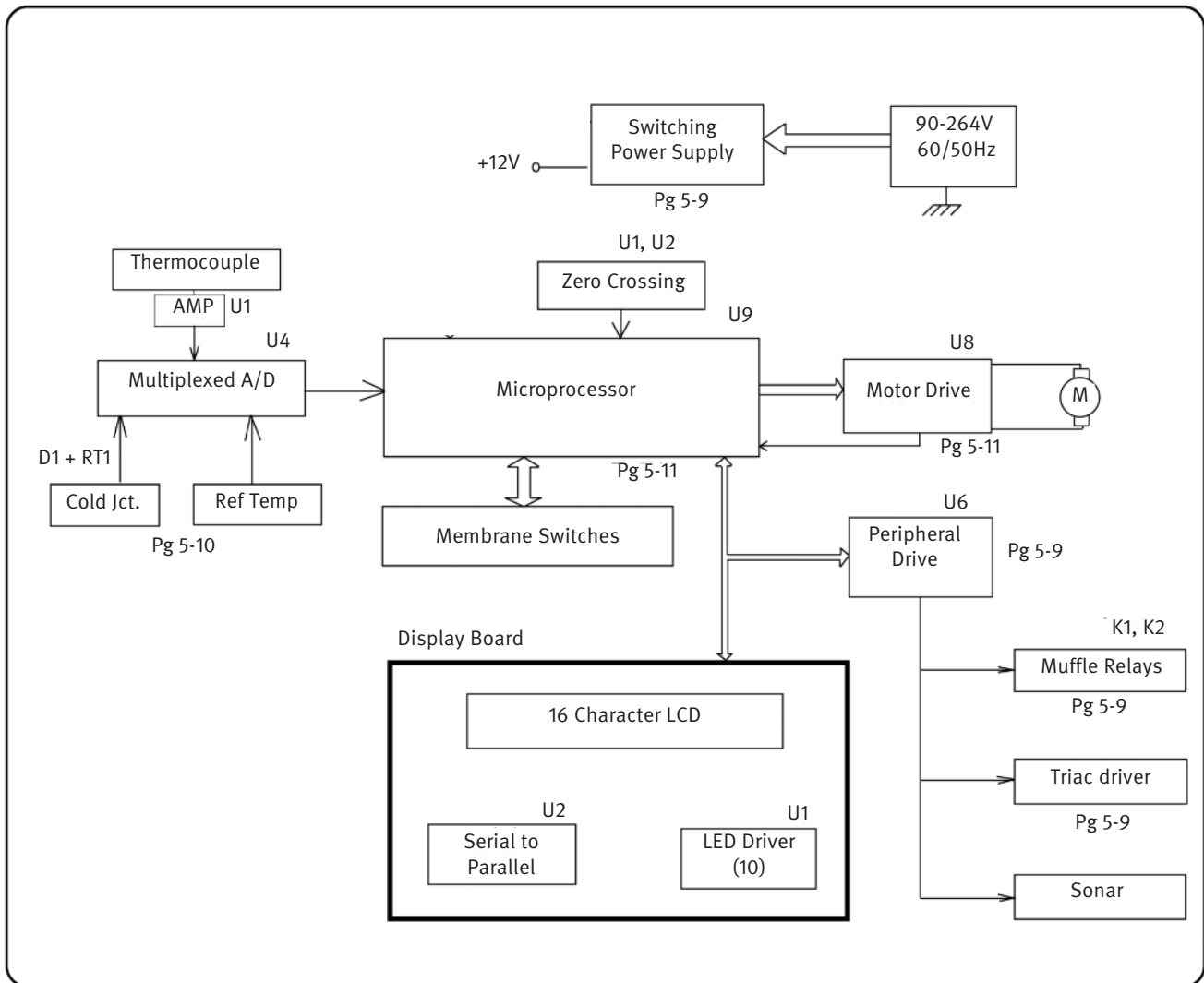

SECTION 5 - TROUBLESHOOTING - 3-STAGE

5.8 SCHEMATICS

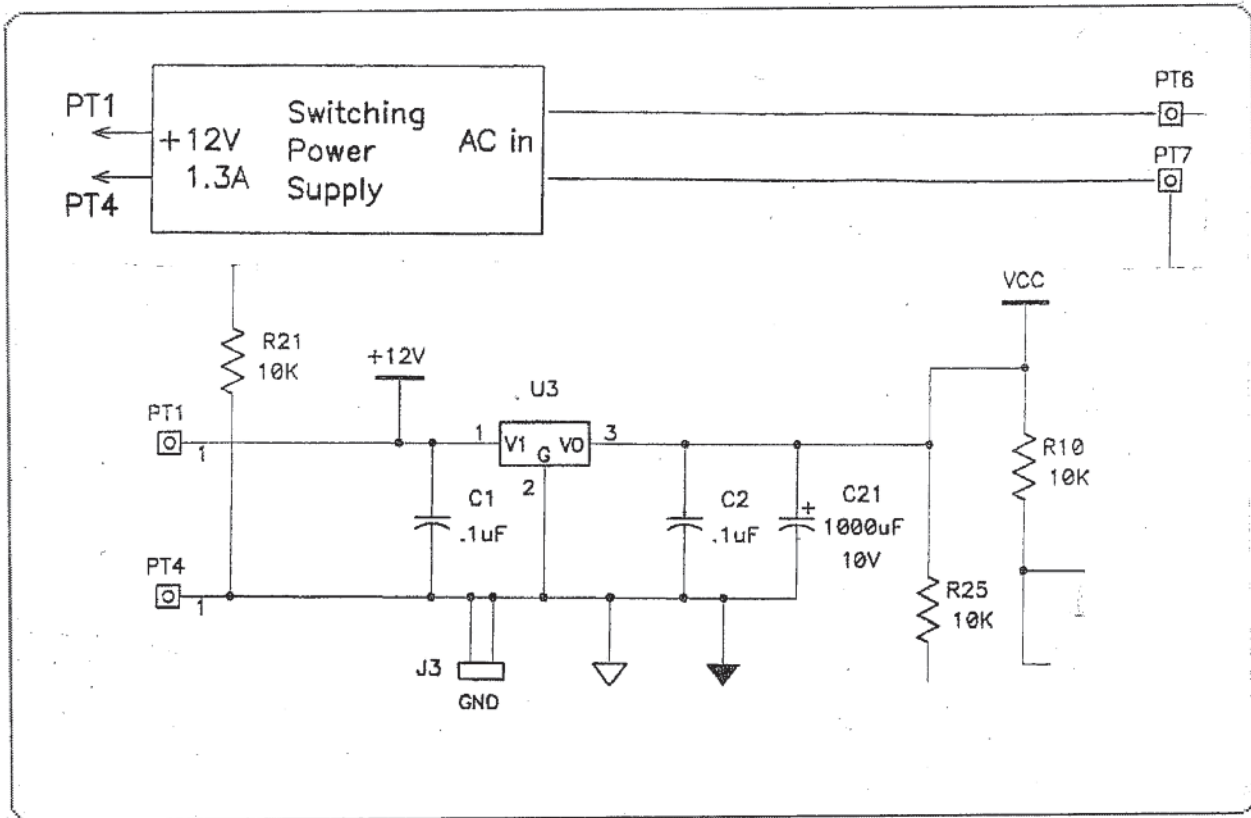

POWER SUPPLY

SECTION 5 - TROUBLESHOOTING - 3-STAGE

5.8 SCHEMATICS

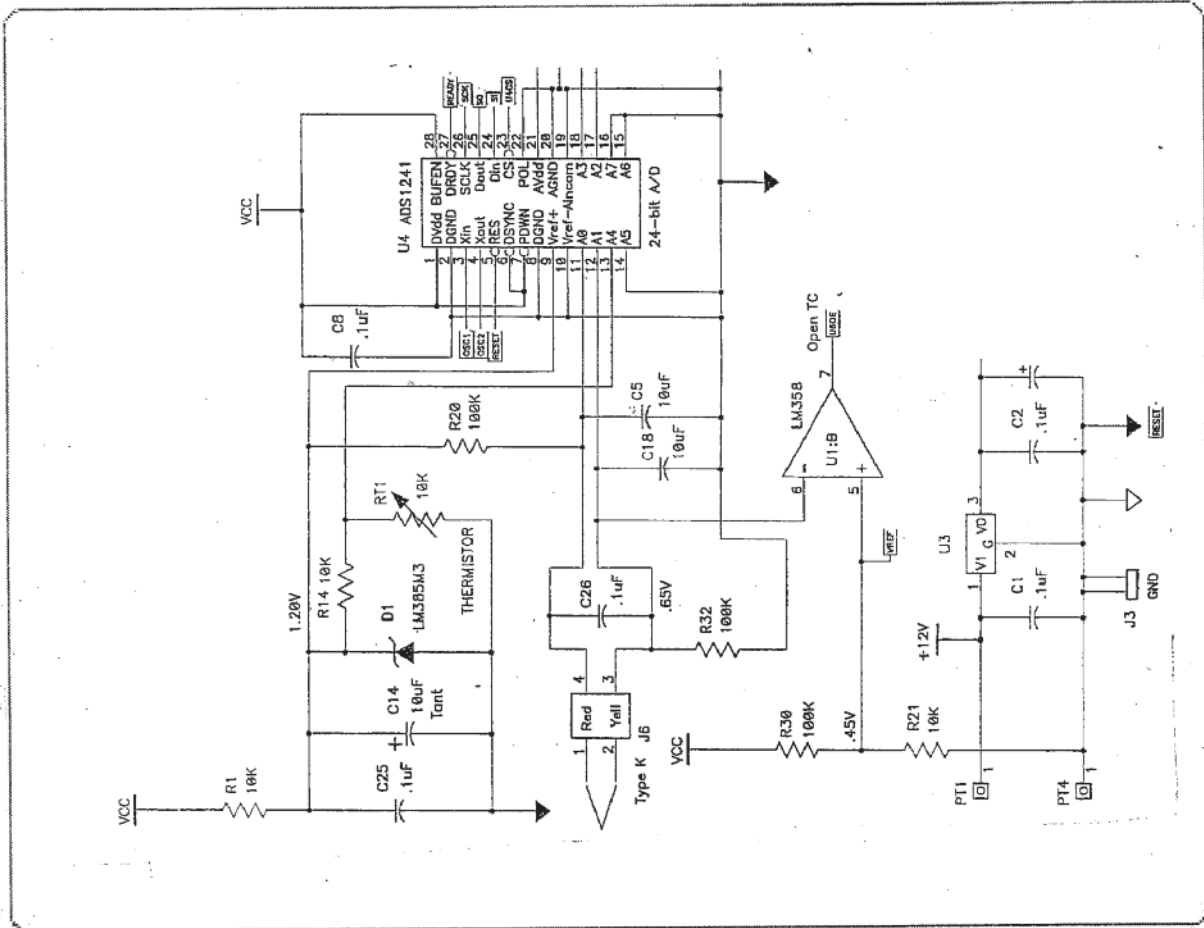

TEMPERATURE CIRCUIT

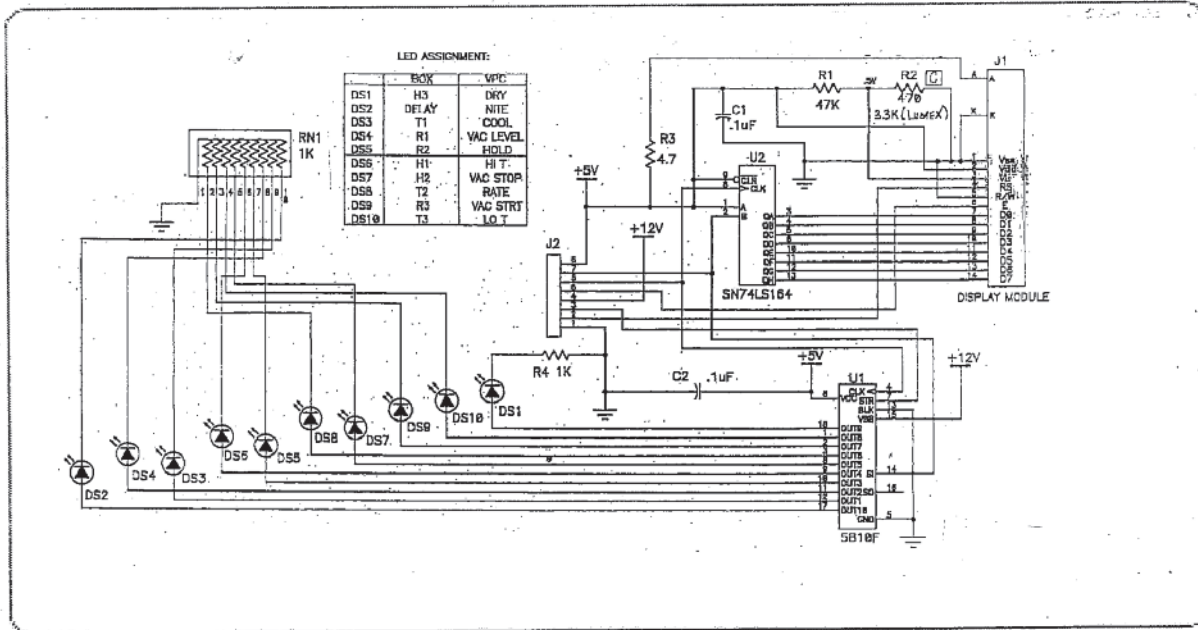

LCD DISPLAY CIRCUIT

SECTION 5 - TROUBLESHOOTING - 3-STAGE

5.8 SCHEMATICS

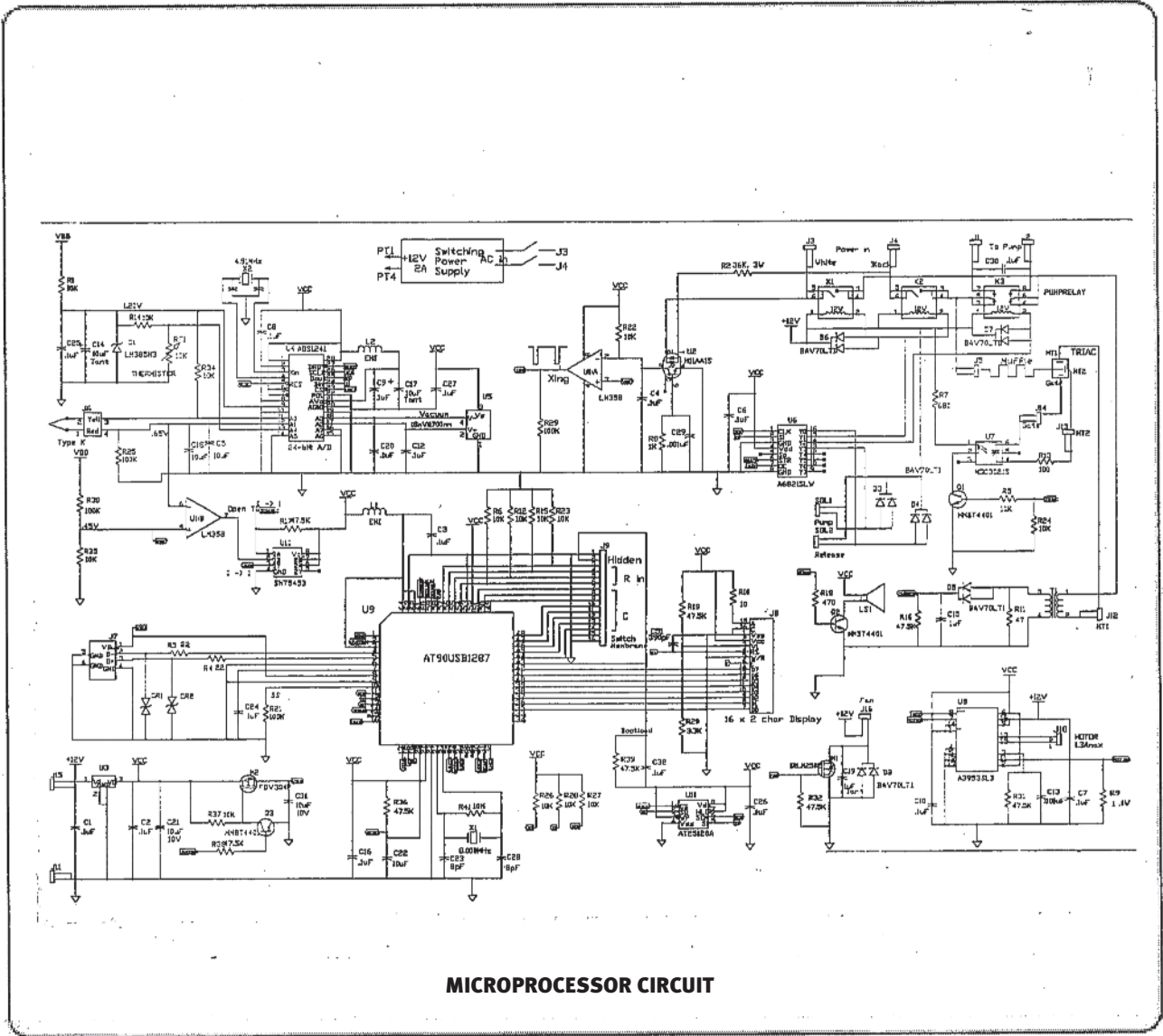

SECTION 5 - TROUBLESHOOTING - 3-STAGE

5.8 SCHEMATICS

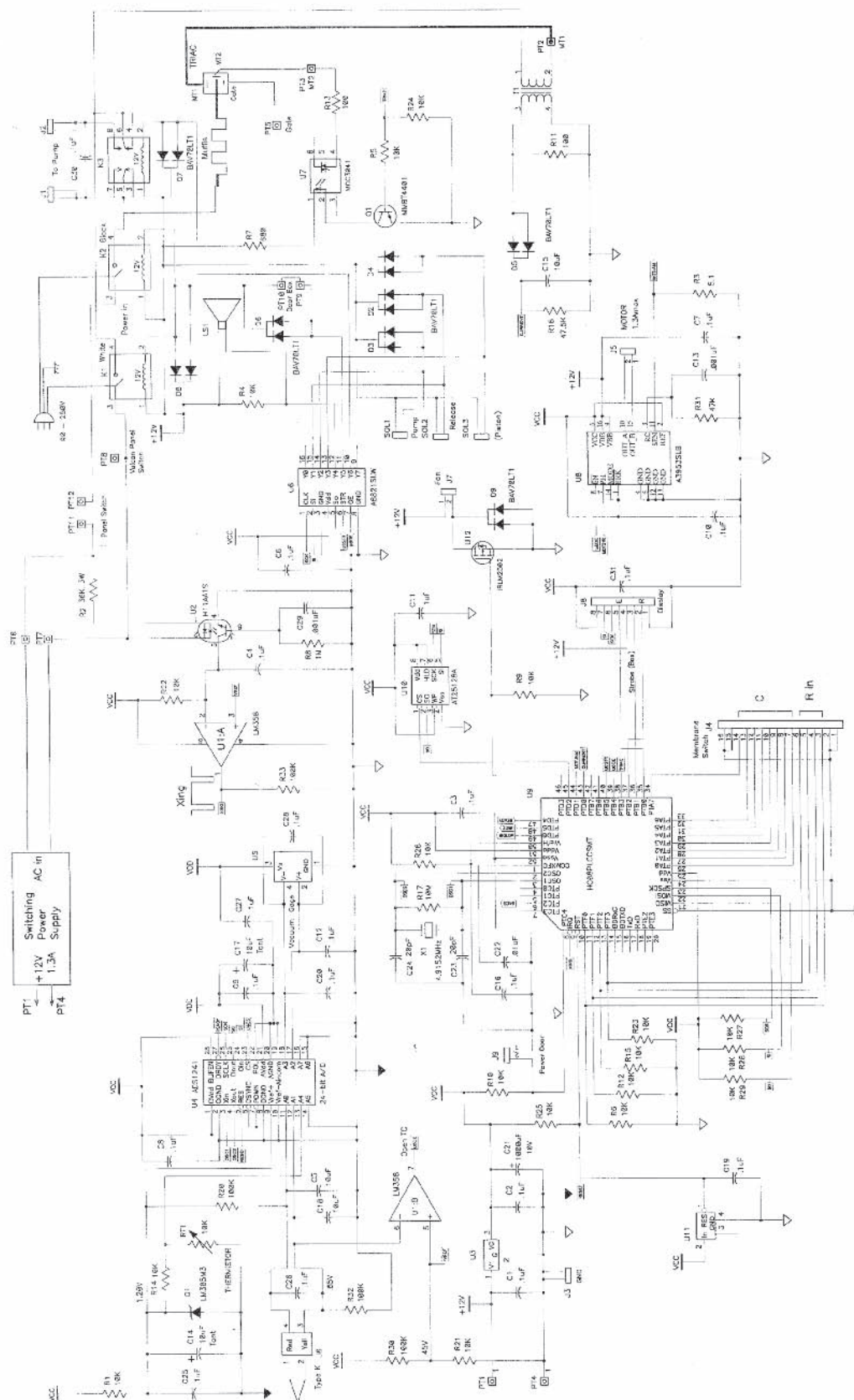

SECTION 5 - TROUBLESHOOTING - 3-STAGE, PD, A

5.9 WIRING DIAGRAM

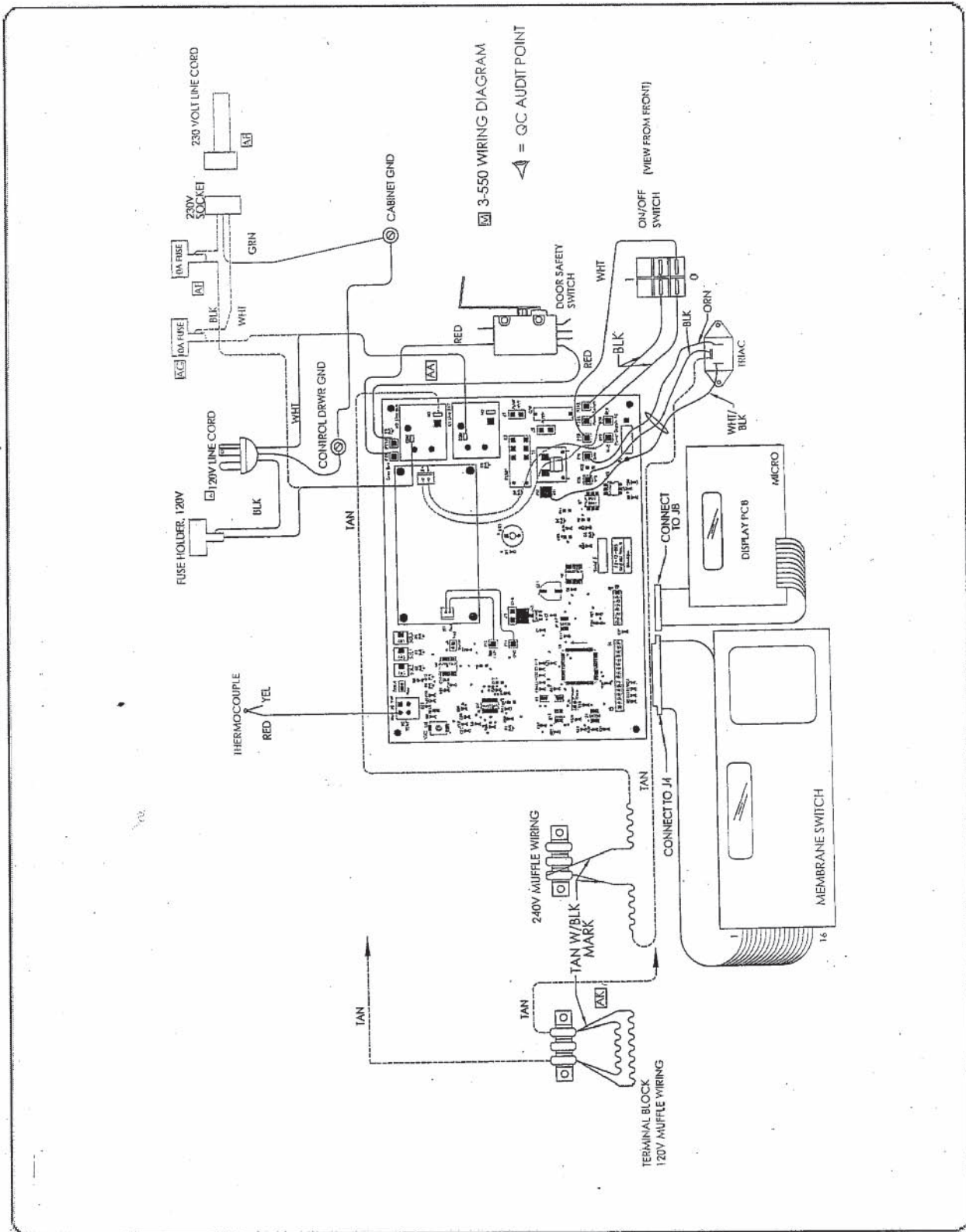

SECTION 6 - ADJUSTMENT/CALIBRATION - 3-STAGE

6.1 SCOPE

This section gives the procedures to be used for the calibration and specification verification of the VULCAN. The furnace specifications are given in the Owner & Operator's Manual.

6.2 FACTORY REPAIR

DENTSPLY Ceramco maintains a factory repair department for those customers not possessing the necessary personnel or test equipment to maintain the VULCAN. If a unit is returned to the factory for calibration or repair, a detailed description of the specific problem should be included to minimize turnaround time. Call factory for PR number before shipping at 1-800-835-6639.

6.3 ADJUSTMENT/CALIBRATION

6.3.1 TEMPERATURE

To verify the muffle temperature at a given setpoint insert the tip of a temperature probe into the exhaust opening far enough to reach the center of the muffle. Connect the other end of the probe to a temperature meter and let the meter reading stabilize. Once a steady reading is obtained on the temperature meter divide the setpoint (display) temperature by the meter temperature and multiply the result by the current Tcal value. The result will be the new Tcal temperature.

Example:

The temperature meter shows a reading of 520°C at a setpoint of 500°C. The Tcal temperature in the setup mode shows 1000°C.

The new setup temperature Tcal is now found by the following calculation:

$$\begin{array}{r} 500^{\circ}\text{C} \\ 520^{\circ}\text{C} \\ \hline \text{Tcal} = .961 \times 1000 = 961^{\circ}\text{C} \end{array}$$

Note: Abort the cycle before turning off the furnace. This is the new Tcal temperature. Turn the furnace off and then on again, wait for Setup? on the display and press ENTER until Tcal = 1000°C appears. Key in 961 and press ENTER.

6.3.2 DOOR, LIFT DRAG ADJUSTMENT

The lift drag force is controlled by a set of friction washers on each of the upper pivot arms. A wave spring should maintain a relatively constant force even after several thousand cycles. If the drag becomes too stiff (too hard to open and close furnace) or too loose an adjustment can be made using the following procedure:

TOOLS REQUIRED: 5/32" Allen Wrench

- Turn the allen head screws on the upper side of the furnace either clockwise to tighten or counterclockwise to loosen the drag force.

Note: Equal adjustment should be made on each side. Turn screws only 1/6 of a revolution at a time when making adjustment.

6.4 CIRCUIT BOARD CALIBRATION

Calibration of the VULCAN circuit board is performed in two steps: Software and hardware.

WARNING

With control drawer opened, dangerous voltage points may be exposed. Contact with any of these points could cause serious injury.

WARNING

Observe antistatic procedures when touching circuit board components which can be damaged by static electricity.

SECTION 7 - SERVICE PARTS - A-CONTROL & 3-STAGE

7.1 ORDERING INSTRUCTIONS

To order parts, select the part number required from the exploded view drawings on page 7.1. through page 7.6. The 130, 550, 1750 numbers refer to the particular size of furnace where the part number is different depending on the size.

When ordering parts please have the following information available:

1. Serial number of furnace.
2. Date purchased.
3. Purchased where.
4. Symptom of failure.
5. Part number of replacement part.
6. Preferred method of shipment.

Hardware Kit: 9493454
(Contains a selection of the fasteners used in the furnaces.)

7.2 MUFFLE AND THERMOCOUPLE

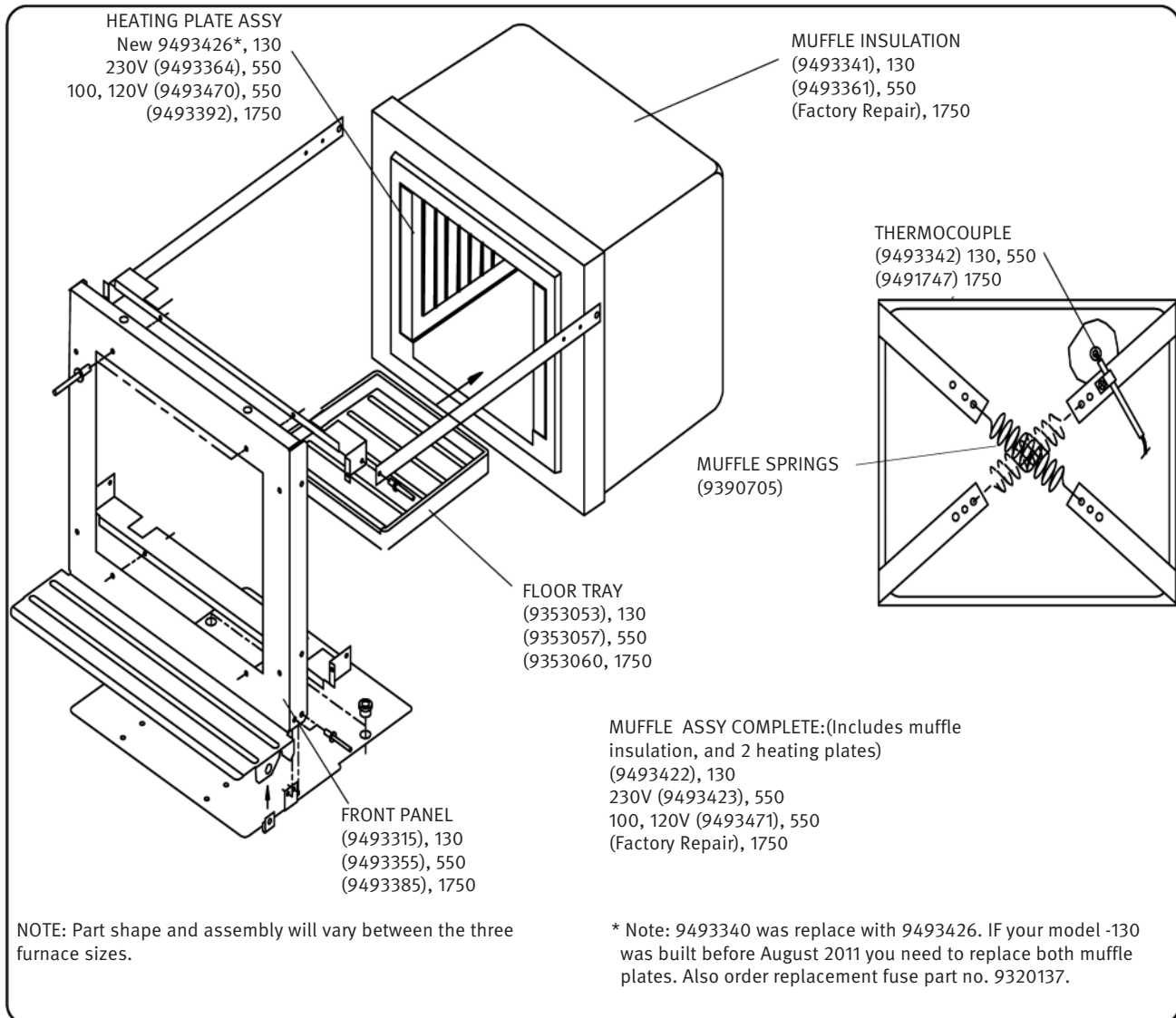

SECTION 7 - SERVICE PARTS - 3-550A & 3-550PD

7.3 MUFFLE (3-550 PD & AIR EXCH)

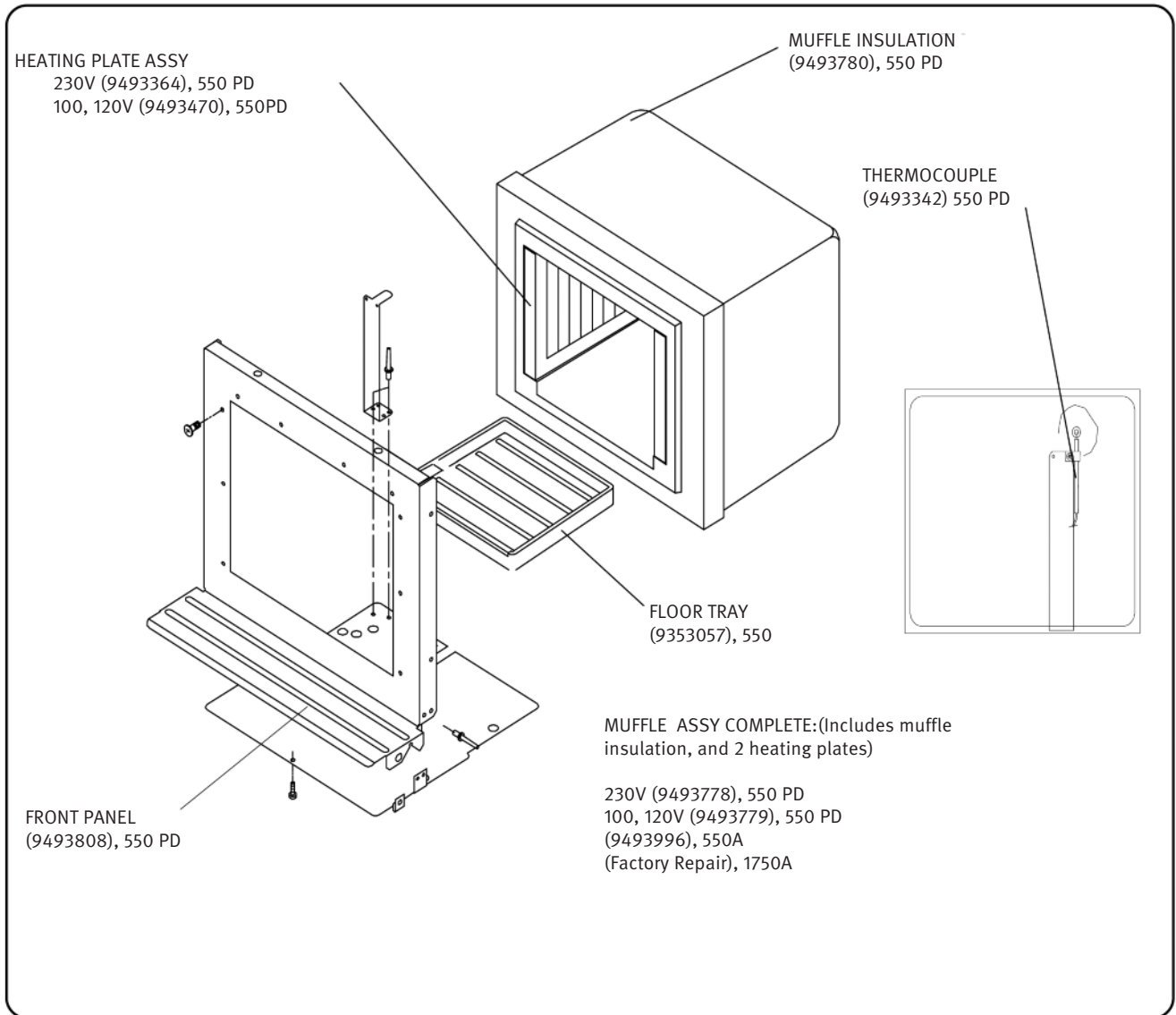

SECTION 7 - SERVICE PARTS - A-CONTROL, 3-STAGE, 3-550PD

7.4 CABINET PARTS

NOTE: To convert to configurations shown, 9495115 - Retrofit Kit, is available for furnaces built prior to S/N 0626xxx.

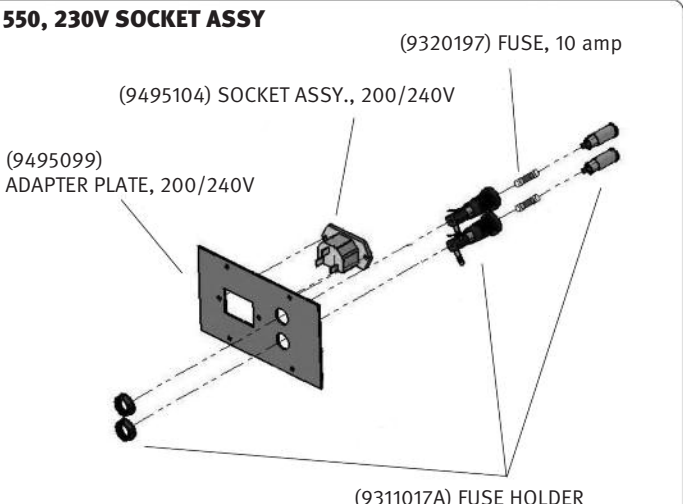
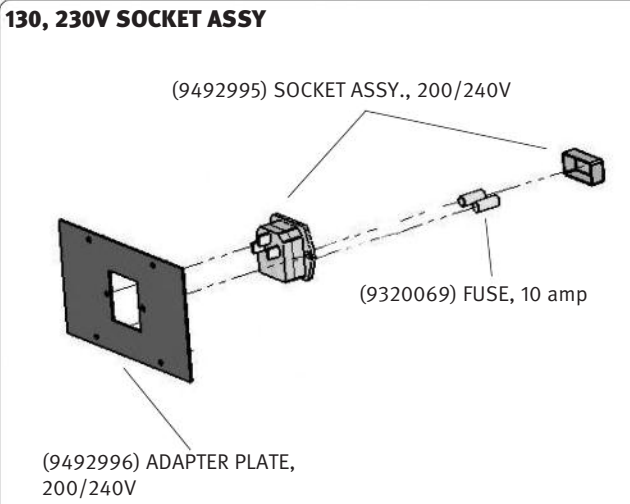
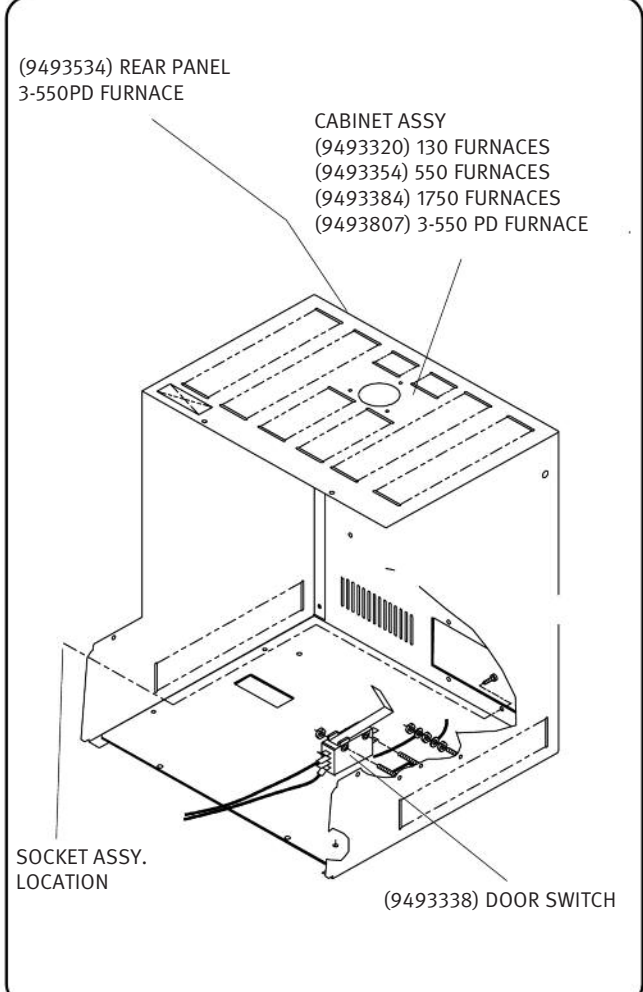
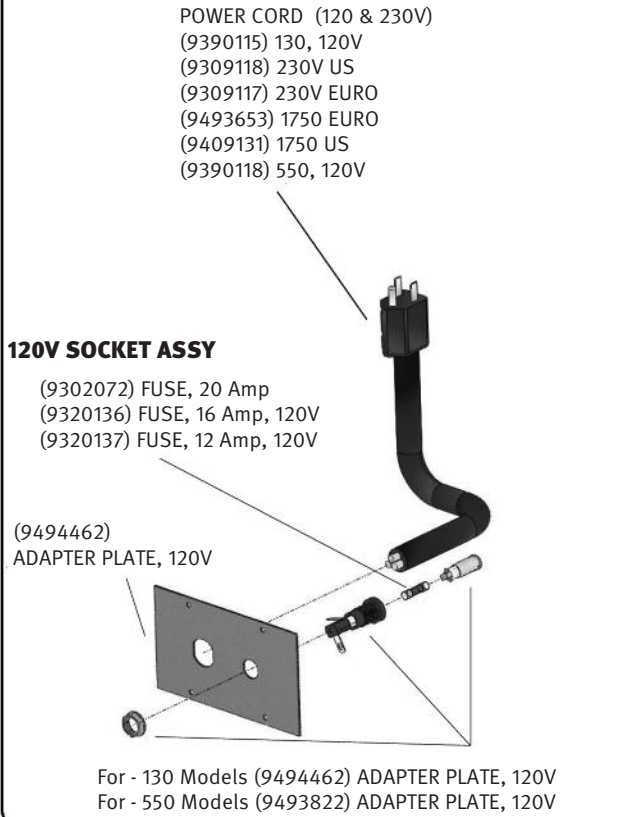

SECTION 7 - SERVICE PARTS - A-CONTROL, 3-STAGE

7.4 CABINET PARTS

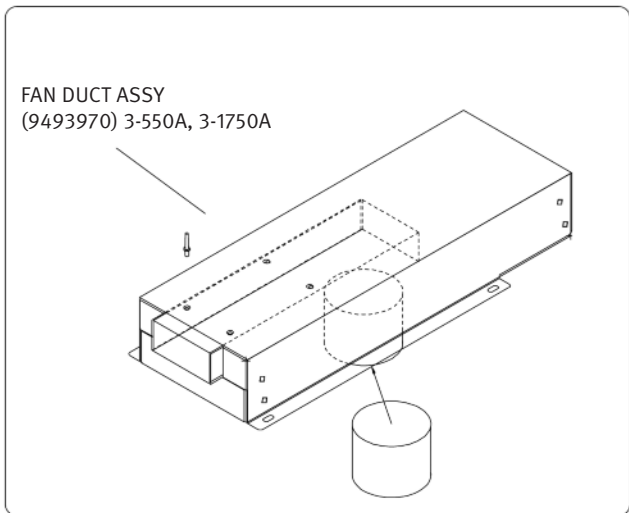
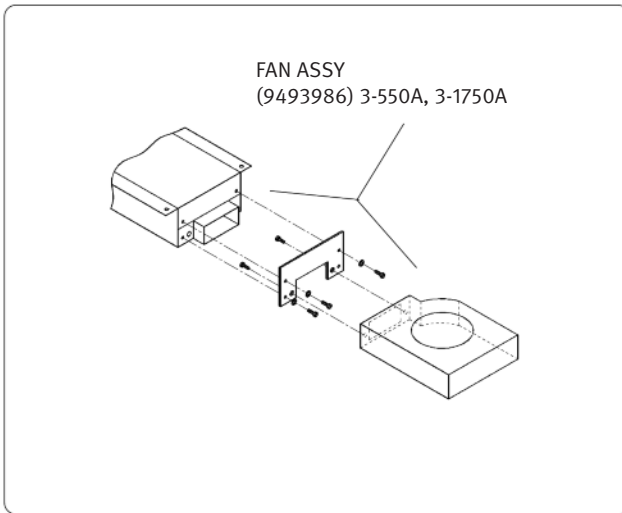

7.5 DOOR PARTS

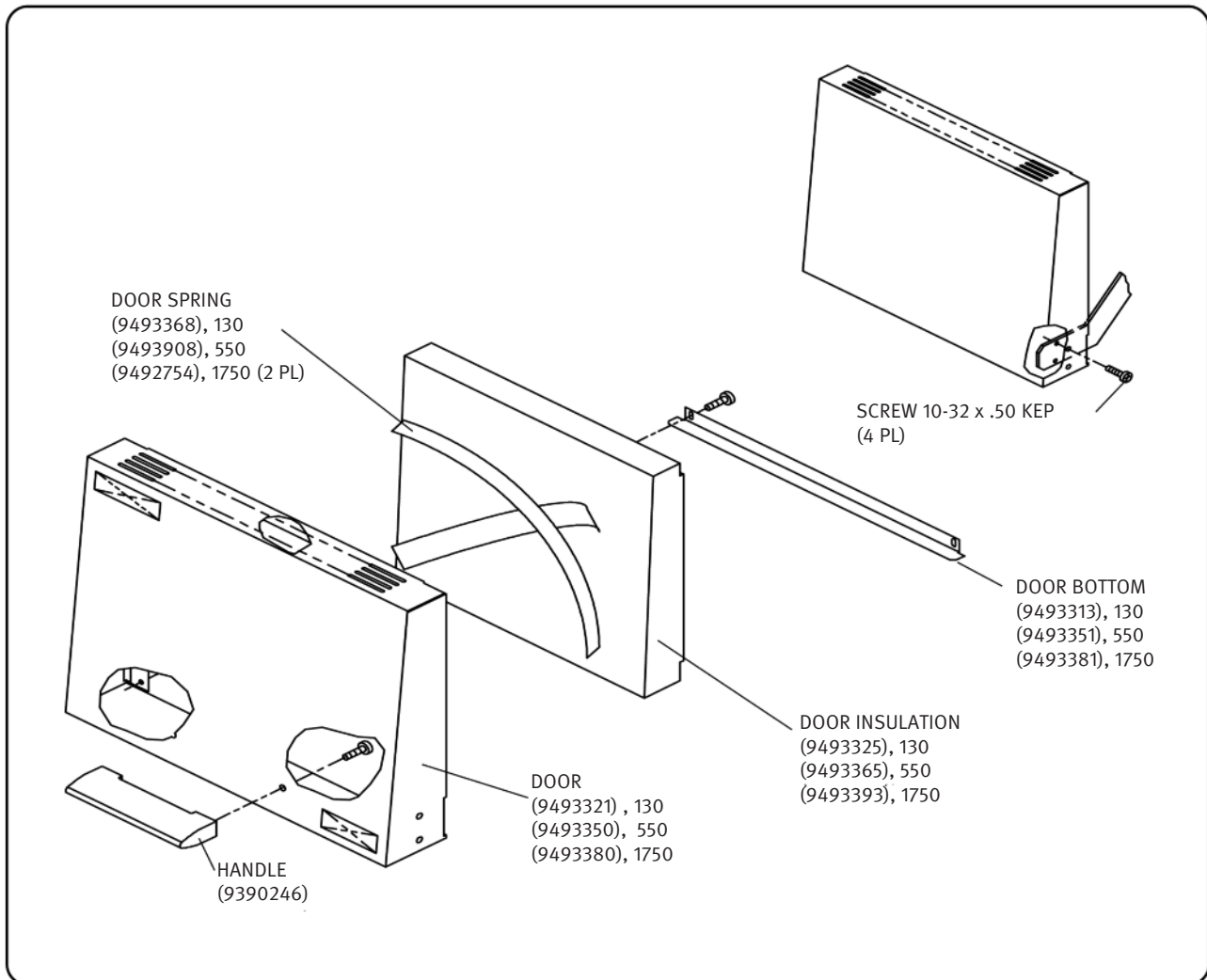

SECTION 7 - SERVICE PARTS - A-CONTROL

7.6 A- CONTROLLER PARTS

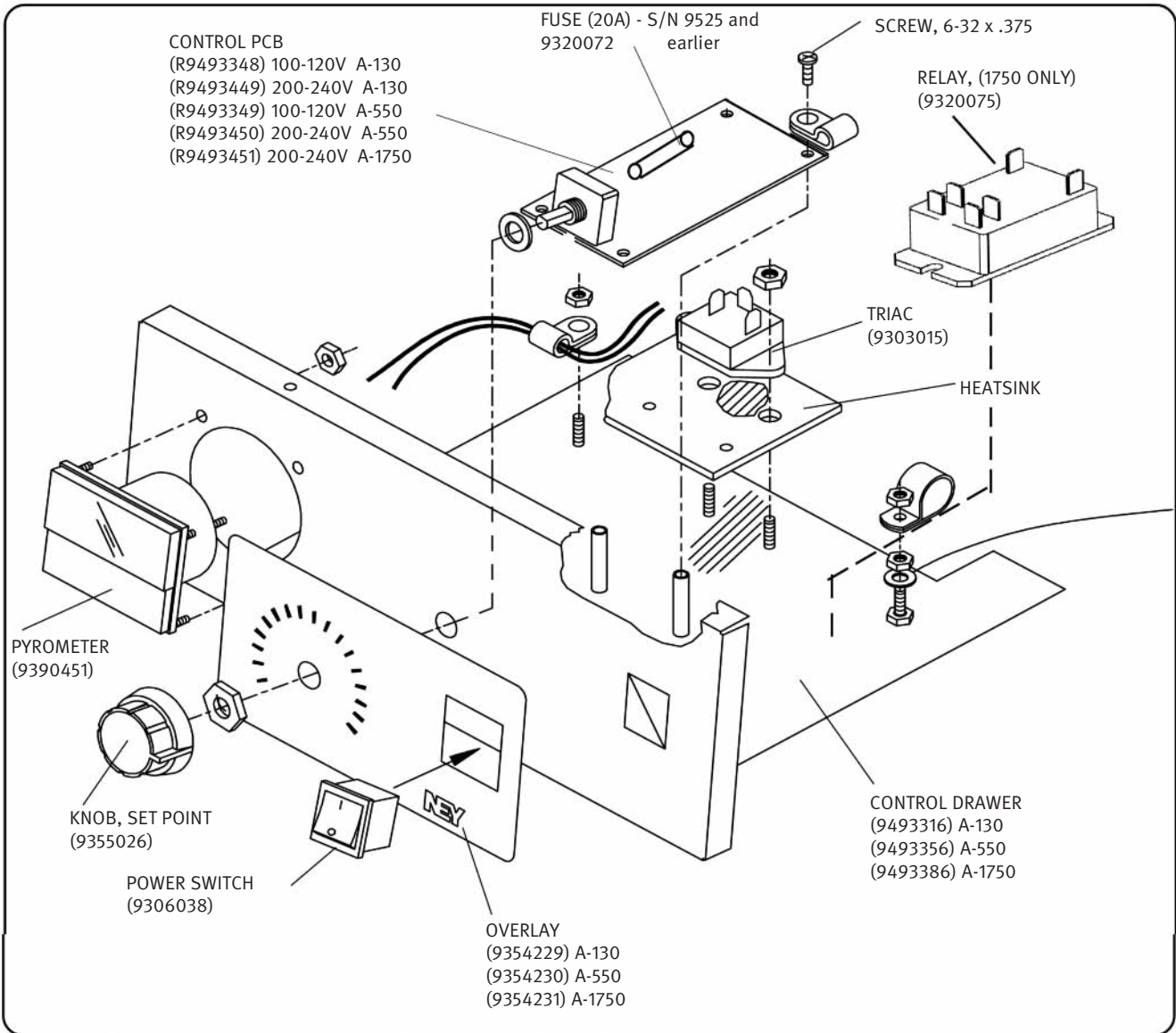

SECTION 7 - SERVICE PARTS - 3-STAGE, 3-550PD

7.7 3-STAGE CONTROLLER PARTS

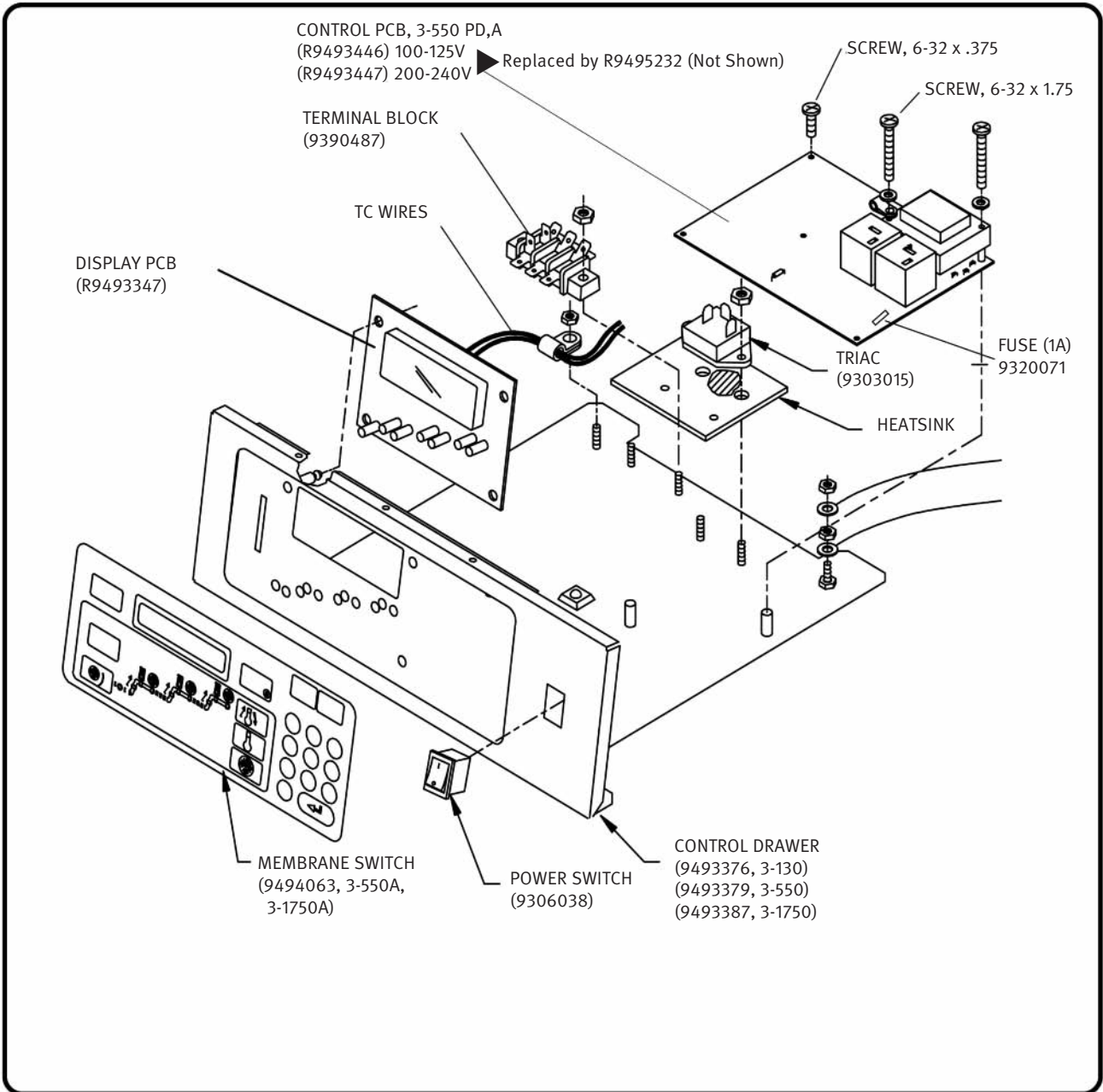

SECTION 7 - SERVICE PARTS - 3-550PD

7.8 LIFT MECHANISM PARTS

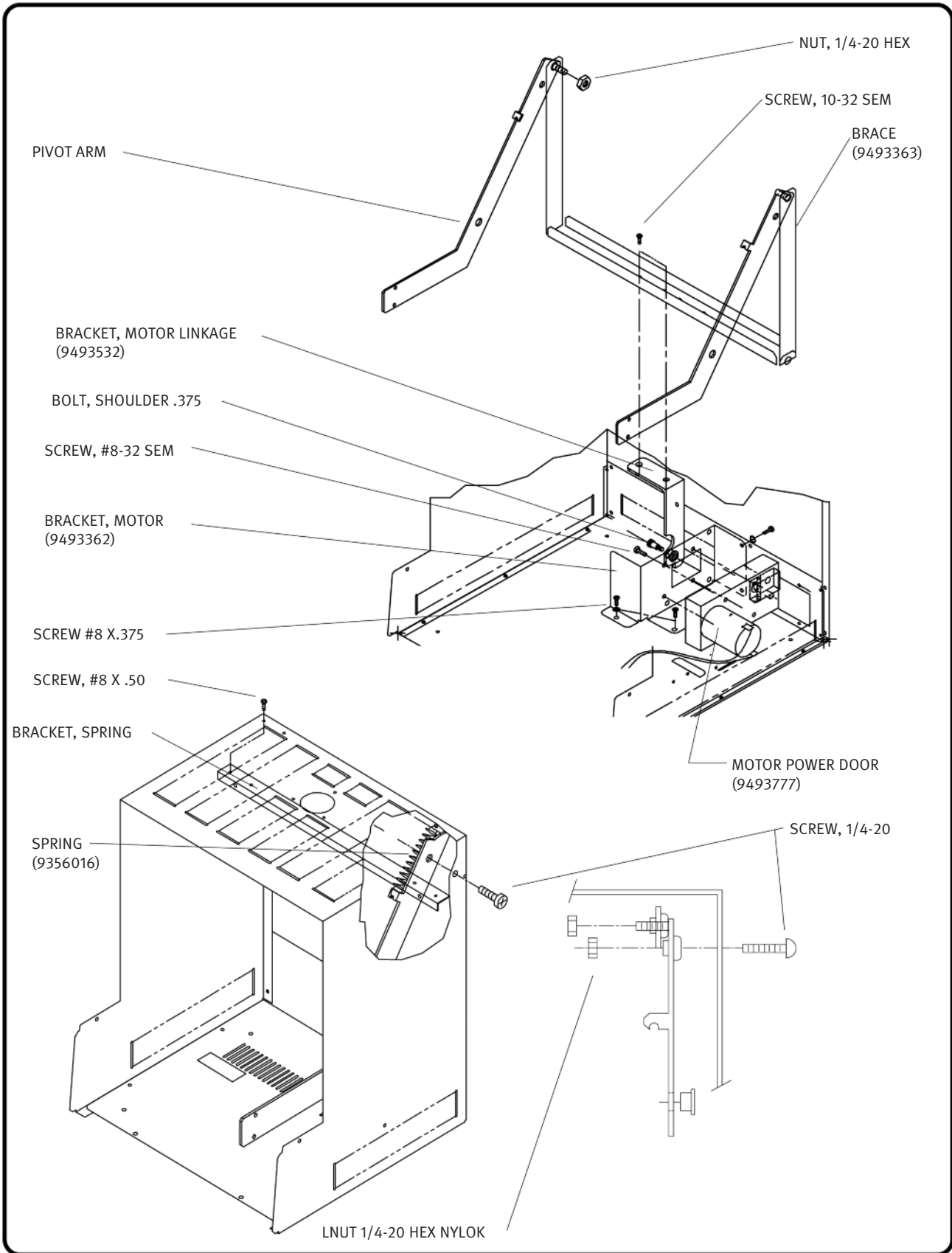

SECTION 8 - DISASSEMBLY/REASSEMBLY - 3-STAGE

8.1 CONTROL DRAWER REMOVAL

TOOLS:

Phillips #2 screwdriver

- To gain access to the electrical components and most other service jobs, removal of the control drawer is required.

WARNING:

Disconnect power cord from wall outlet before attempting to service the furnace.

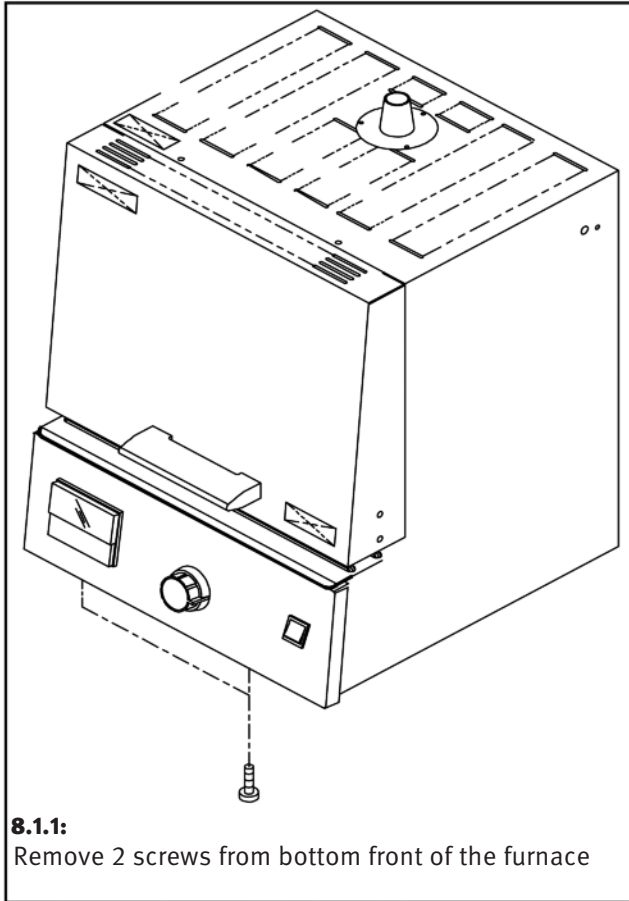

8.1.1:
Remove 2 screws from bottom front of the furnace

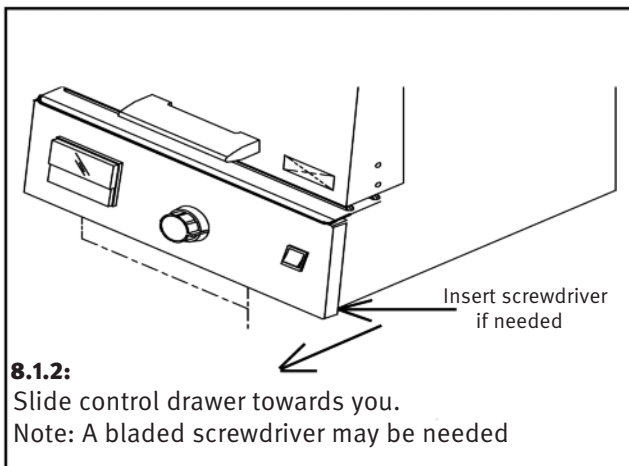

8.1.2:
Slide control drawer towards you.
Note: A bladed screwdriver may be needed

8.2 TRIAC

TOOLS:

Phillips #2 screwdriver, 1/4" nut driver, needle nose pliers

8.2.1:

Follow steps 8.1.1 through 8.1.2 of CONTROL DRAWER REMOVAL

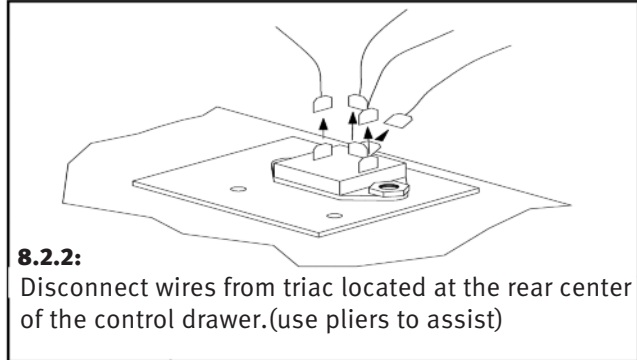

8.2.2:
Disconnect wires from triac located at the rear center of the control drawer.(use pliers to assist)

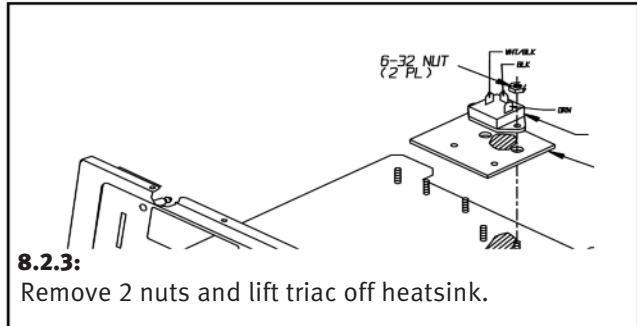

8.2.3:
Remove 2 nuts and lift triac off heatsink.

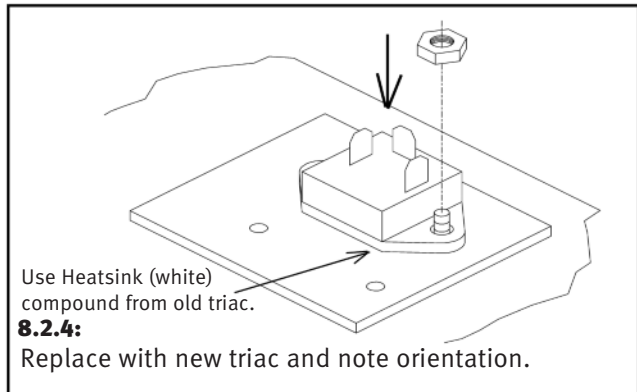

8.2.4:
Replace with new triac and note orientation.

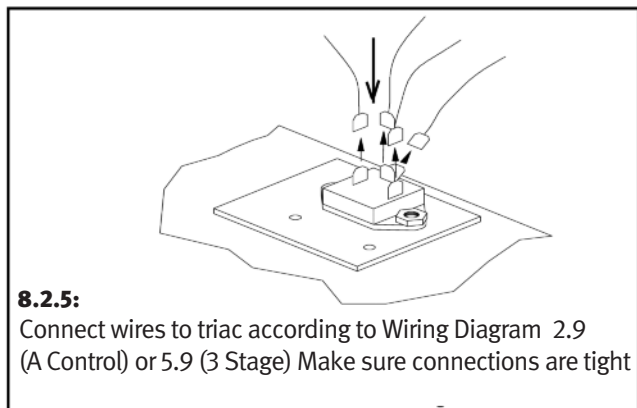

8.2.5:
Connect wires to triac according to Wiring Diagram 2.9 (A Control) or 5.9 (3 Stage) Make sure connections are tight

SECTION 8 - DISASSEMBLY/REASSEMBLY - 3-STAGE

8.3 MEMBRANE SWITCH

TOOLS:

Phillips screwdriver

Knife of other sharp edged device

8.3.1:

Follow steps 8.1.1 through 8.1.2 of CONTROL DRAWER REMOVAL

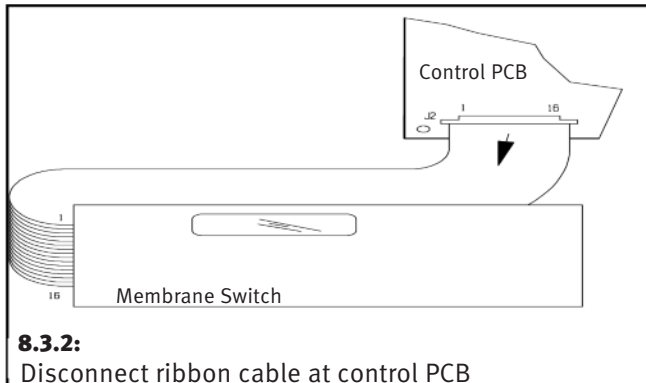

8.3.2:

Disconnect ribbon cable at control PCB

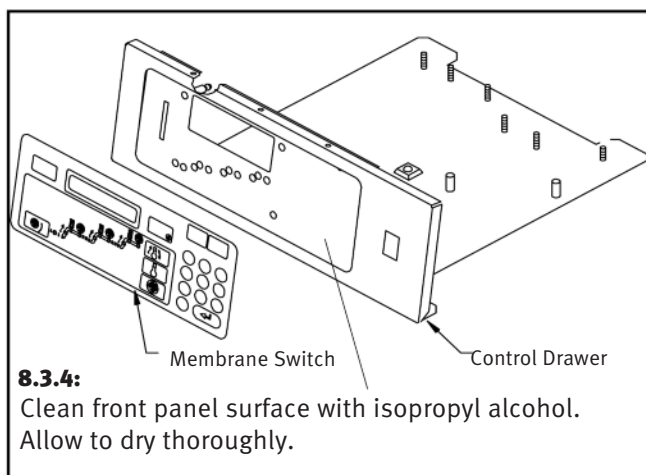
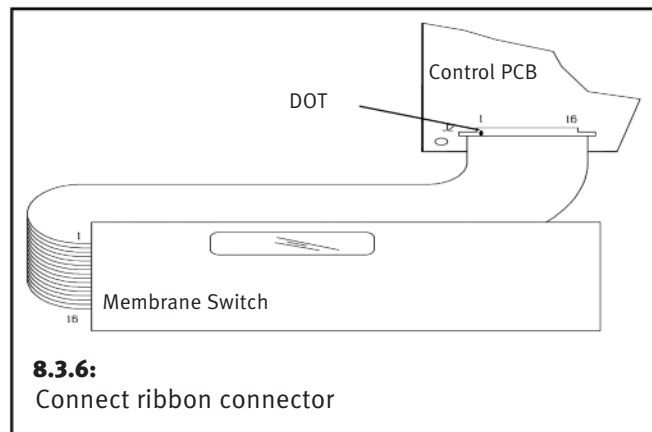
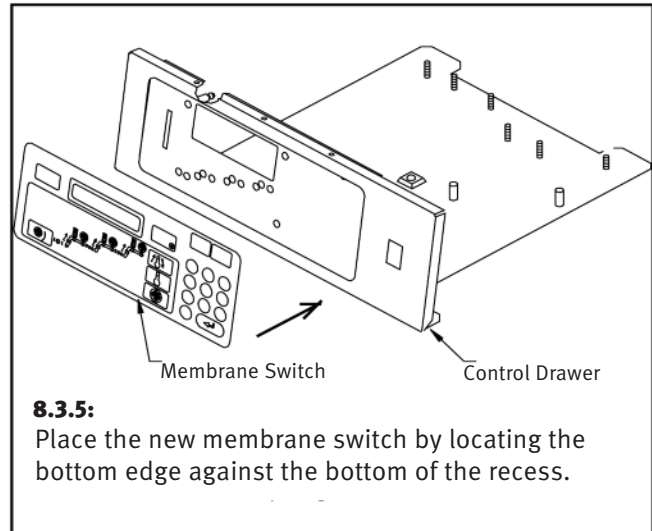
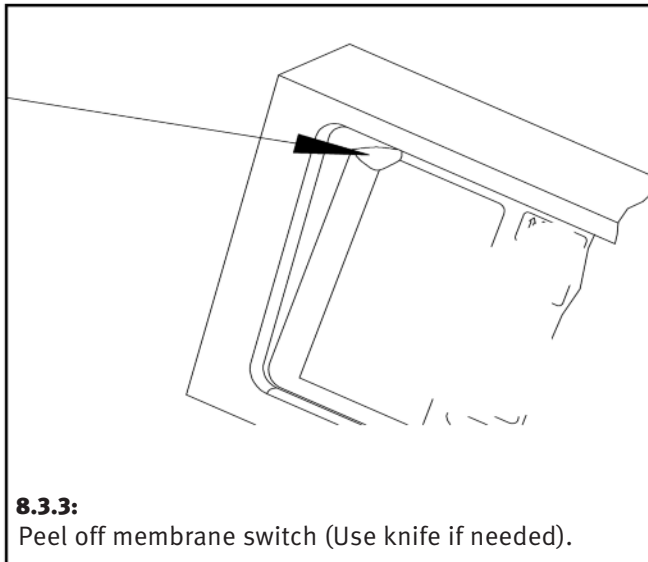

SECTION 8 - DISASSEMBLY/REASSEMBLY - 3-STAGE

8.4 DISPLAY PCB

TOOLS: Phillips screwdriver

CAUTION!

Use proper ESD grounding techniques when handling electronic components

8.4.1:

Follow steps 8.1.1 through 8.1.2 of CONTROL DRAWER REMOVAL

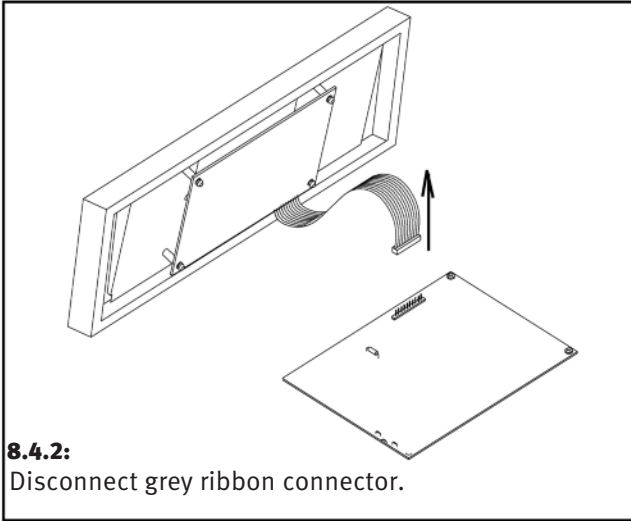

8.4.2:

Disconnect grey ribbon connector.

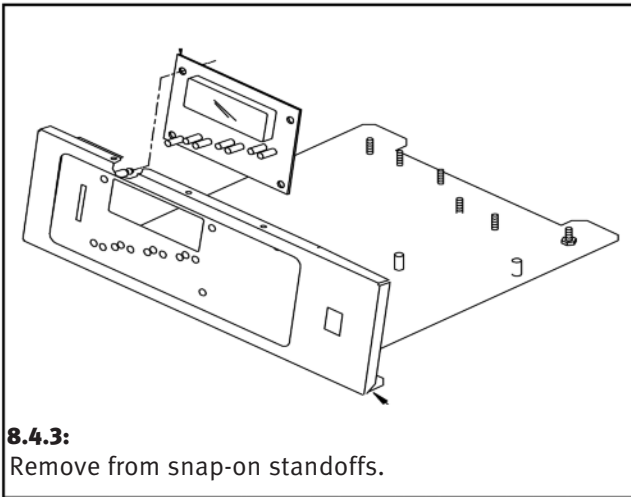

8.4.3:

Remove from snap-on standoffs.

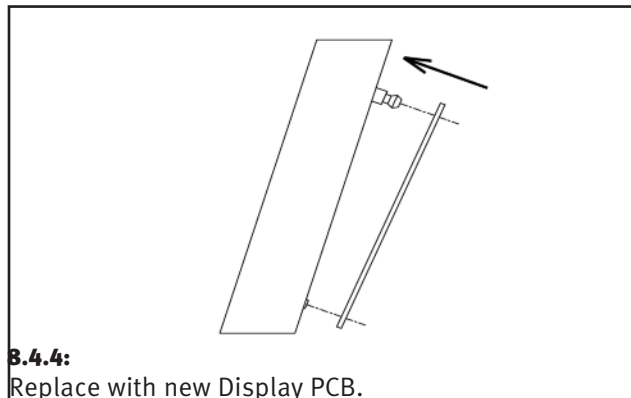

8.4.4:

Replace with new Display PCB.

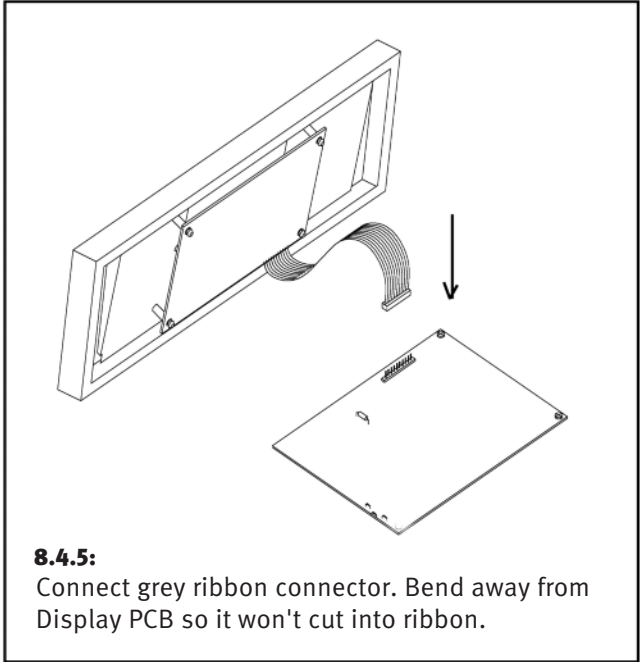

8.4.5:

Connect grey ribbon connector. Bend away from Display PCB so it won't cut into ribbon.

SECTION 8 - DISASSEMBLY/REASSEMBLY - A-CONTROL

8.5 A-CONTROL PCB

TOOLS:

Phillips screwdriver
 Needle nose pliers
 3/8" nut driver or wrench
 1/4" nut driver
 13 mm nut driver or pliers

CAUTION!

Use proper ESD grounding techniques when handling electronic component

8.5.1:

Follow steps 8.1.1 through 8.1.2 of CONTROL DRAWER REMOVAL.

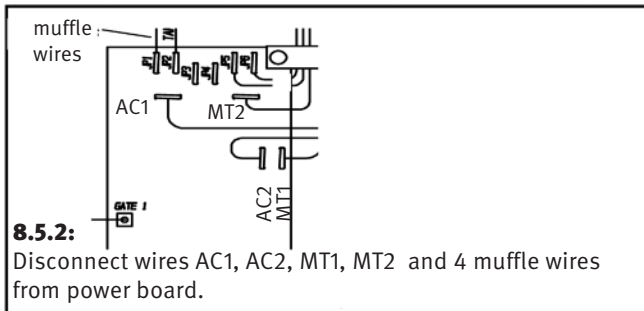

8.5.2:

Disconnect wires AC1, AC2, MT1, MT2 and 4 muffle wires from power board.

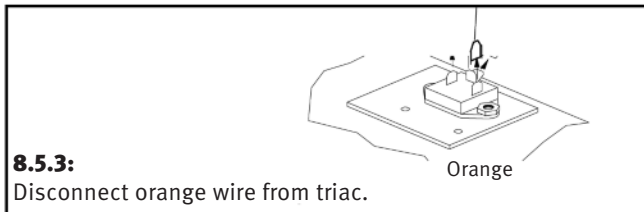

8.5.3:

Disconnect orange wire from triac.

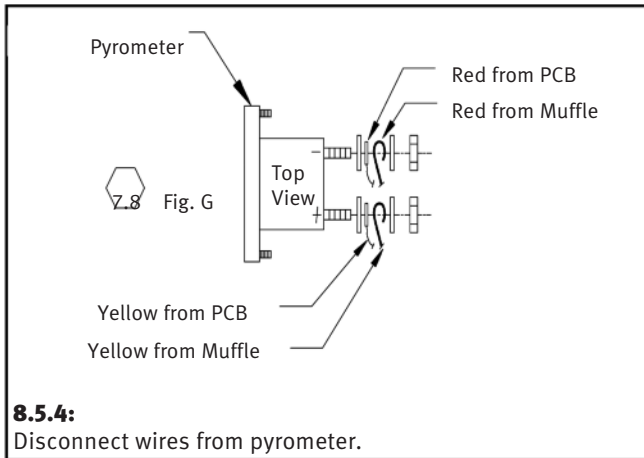

8.5.4:

Disconnect wires from pyrometer.

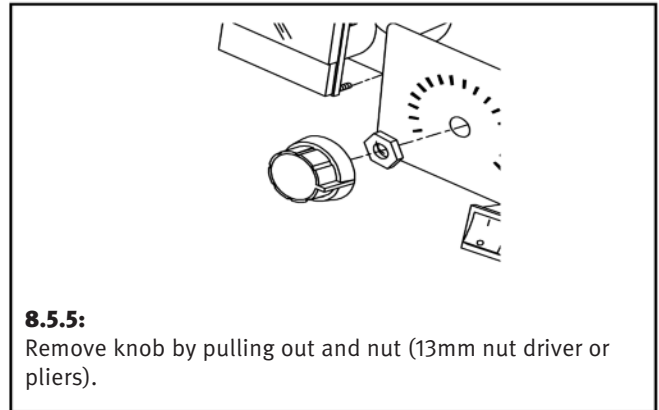

8.5.5:

Remove knob by pulling out and nut (13mm nut driver or pliers).

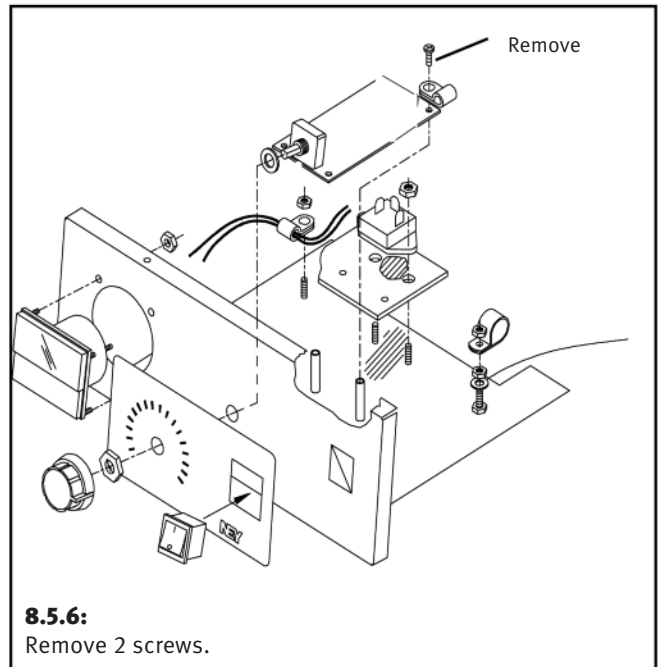

8.5.6:

Remove 2 screws.

Reverse steps for reassembly.

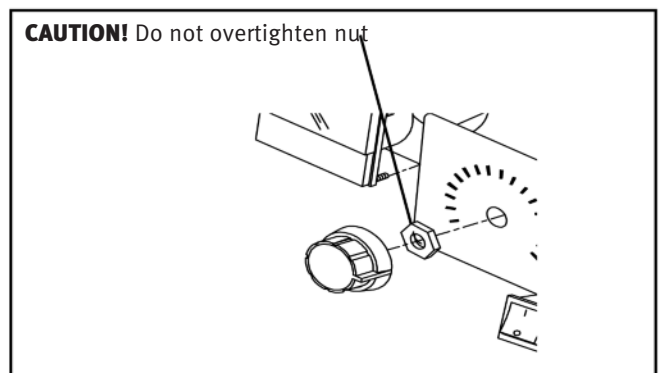

CAUTION! Do not overtighten nut

SECTION 8 - DISASSEMBLY/REASSEMBLY - 3-STAGE

8.6A 3 STAGE CONTROL PCB - 9493980

TOOLS:

Phillips screwdriver, Slotted screwdriver, Needle nose pliers

CAUTION!

Use proper ESD grounding techniques when handling electronic components

8.6.1: Follow steps 8.1.1 through 8.1.2 of CONTROL DRAWER REMOVAL.

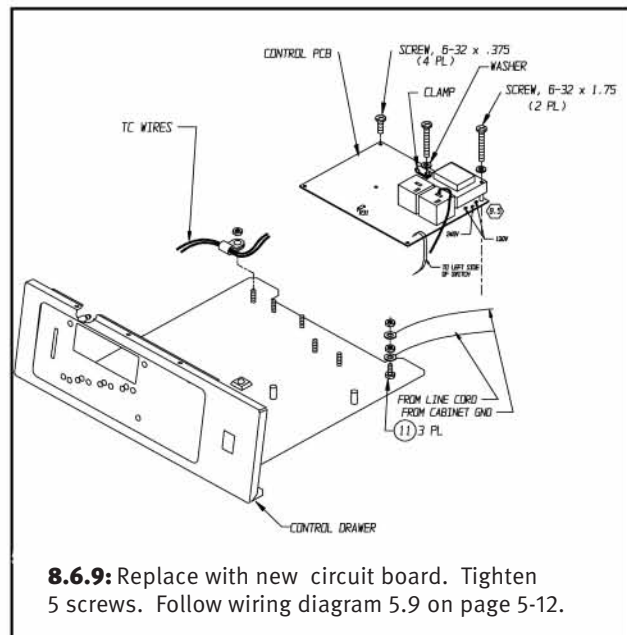
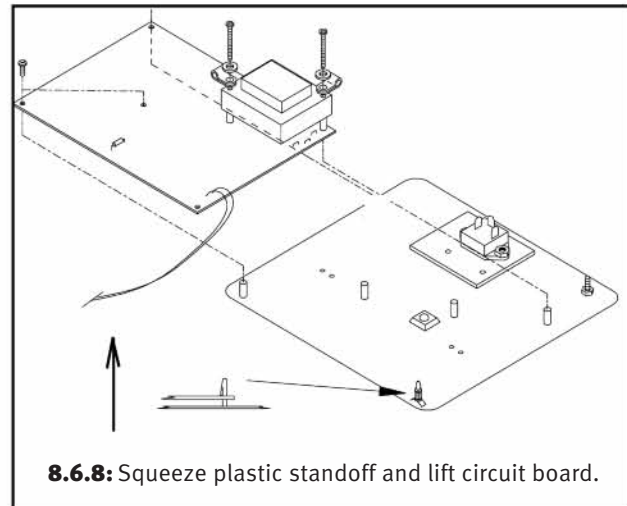
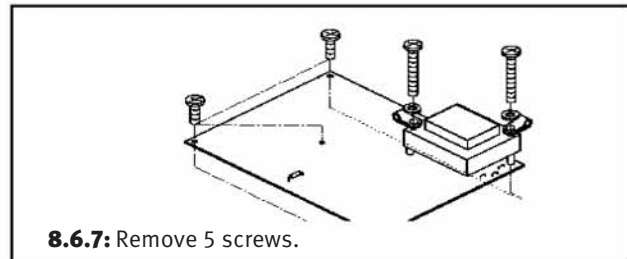
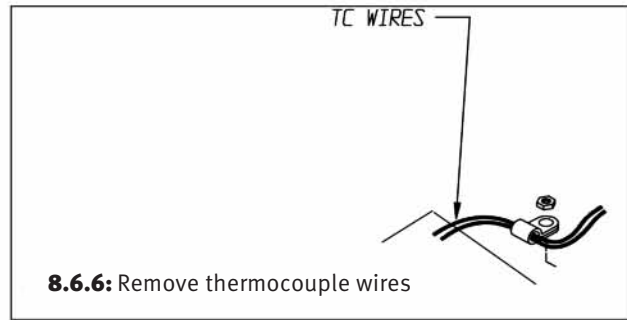
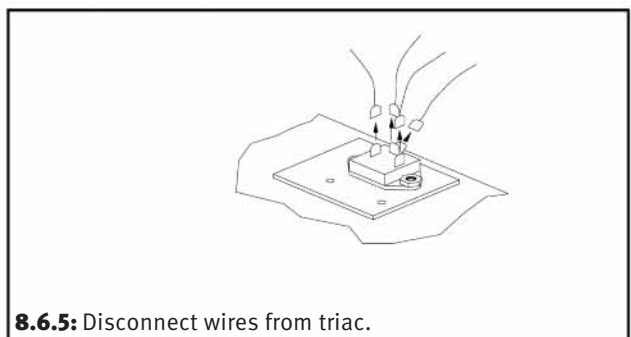
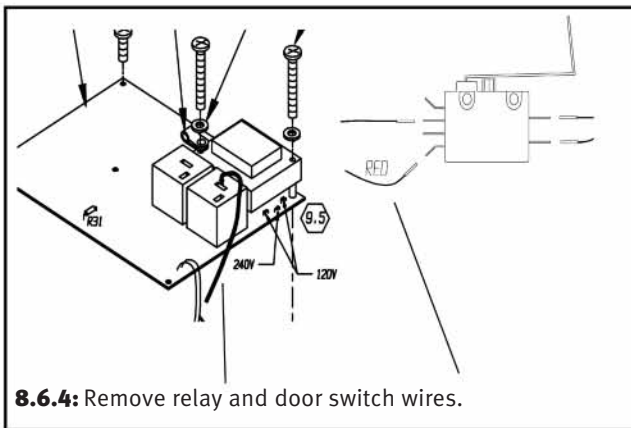
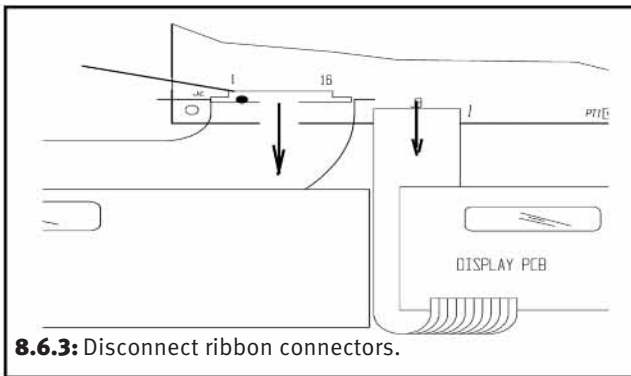
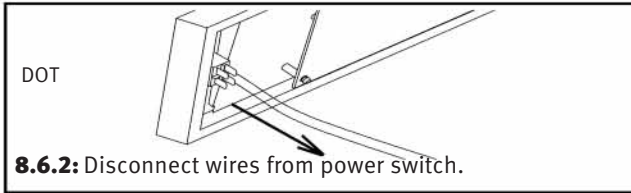

SECTION 8 - DISASSEMBLY/REASSEMBLY

8.6B 3 STAGE CONTROL PCB – 9495232

TOOLS:

Phillips & Slotted Screwdrivers, Needle Nose Pliers

Follow steps 8.1.1 through 8.1.2 of Control Drawer

CAUTION!

Use proper ESD grounding techniques when handling components

REMOVAL

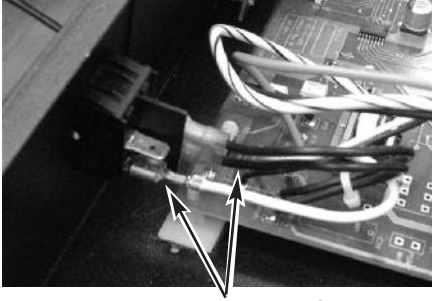

Figure 1 - Disconnect wires from Power Switch

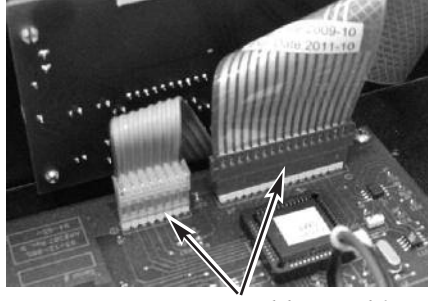

Figure 2 - Disconnect Ribbon Cables

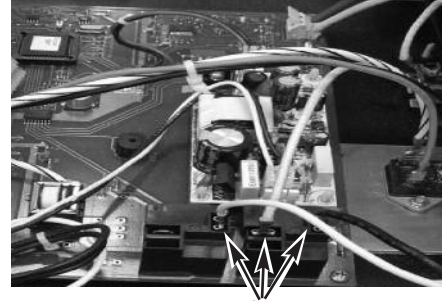

Figure 3 - Remove Relay Wires

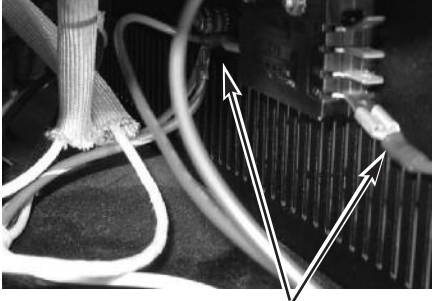

Figure 4 - Remove Door Switch Wires

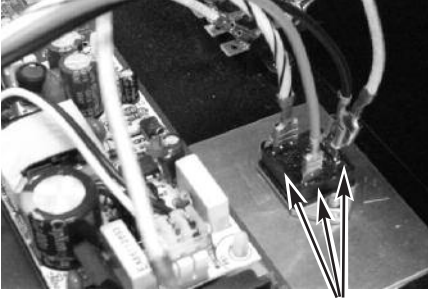

Figure 5 - Remove Wire From Triac

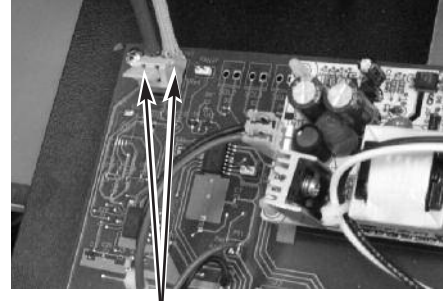

Figure 6 - Remove Thermocouple Wires

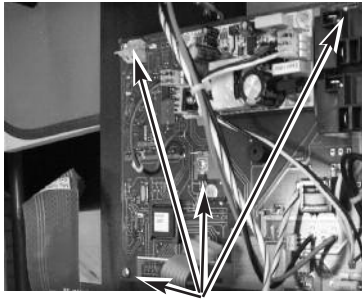

Figure 7 - Remove 4 Screws from PCB

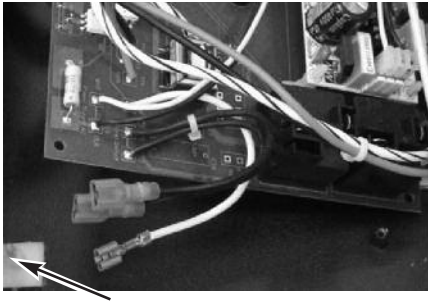

Figure 8 - Squeeze standoff with needle nose pliers & remove PCB

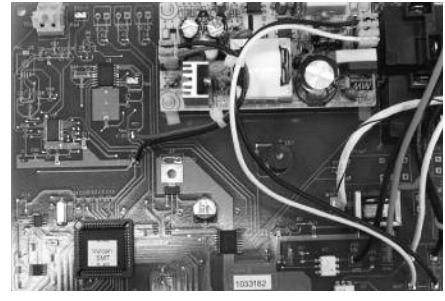

Figure 9 - New PCB Replacement

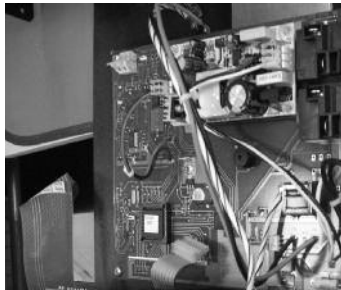

Figure 10 - Insert PCB in standoff, tighten 4 Screws



Figure 11 - Follow Steps #1 thru #6 for PCB Connections

SECTION 8 - DISASSEMBLY/REASSEMBLY

8.7 DOOR ASSEMBLY/ ADJUSTMENT

TOOLS:

5/32 Allen wrench

Phillips head screwdriver

If the door feels too stiff or too loose when lifting up and down, a tension adjustment can be made from the outside.

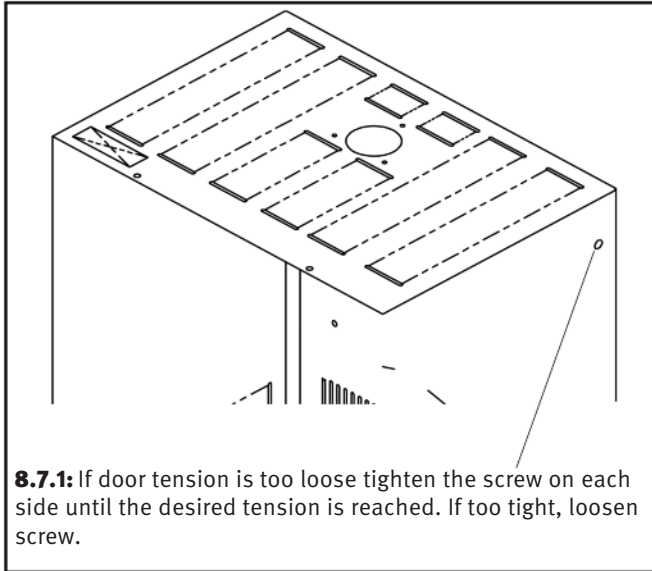

8.7.1: If door tension is too loose tighten the screw on each side until the desired tension is reached. If too tight, loosen screw.

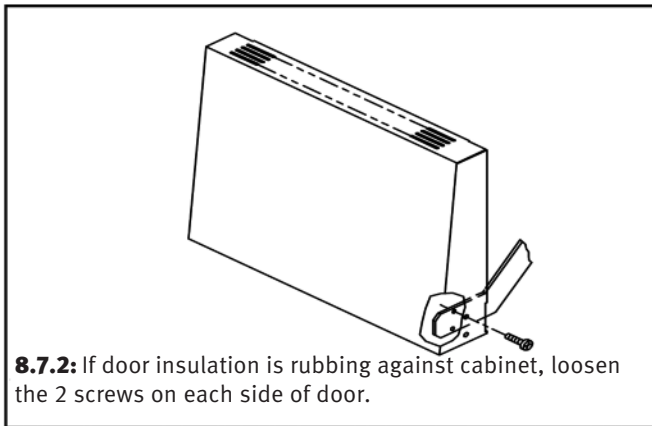

8.7.2: If door insulation is rubbing against cabinet, loosen the 2 screws on each side of door.

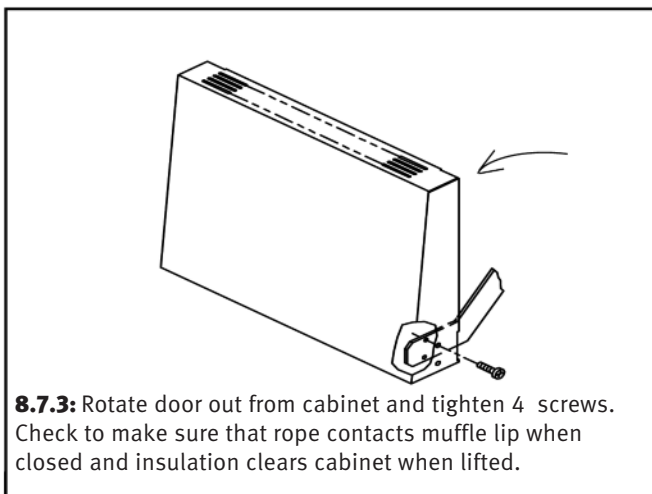

8.7.3: Rotate door out from cabinet and tighten 4 screws. Check to make sure that rope contacts muffle lip when closed and insulation clears cabinet when lifted.

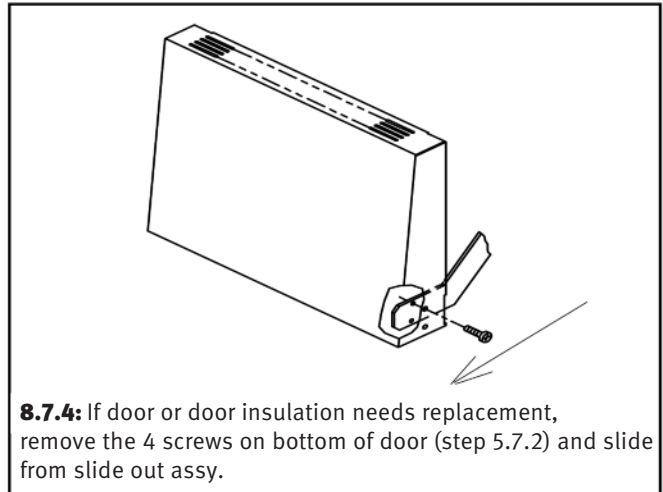

8.7.4: If door or door insulation needs replacement, remove the 4 screws on bottom of door (step 5.7.2) and slide from slide out assy.

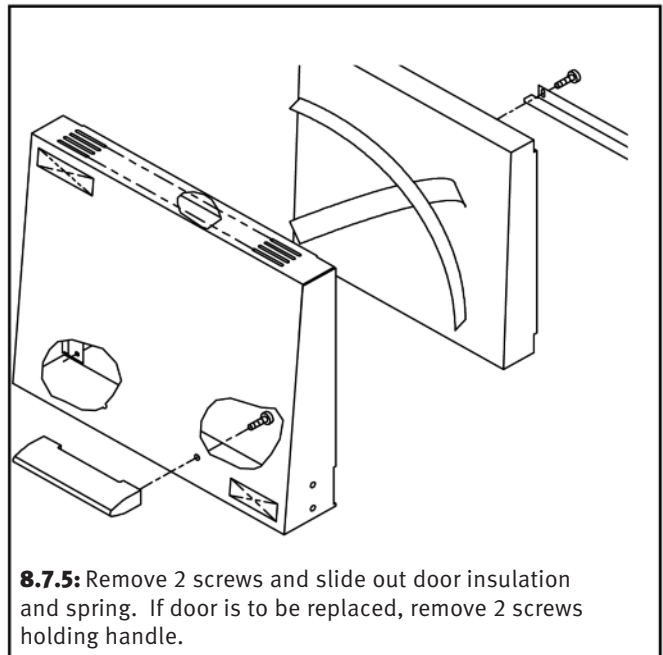

8.7.5: Remove 2 screws and slide out door insulation and spring. If door is to be replaced, remove 2 screws holding handle.

8.7.6: Replace with new insulation or door by reversing steps 8.7.4 - 8.7.5.

8.7.7: Set spacing as described in section 8.7.3. Important! Screws must be torqued to 25-30 in-lbs.

SECTION 8 - DISASSEMBLY/REASSEMBLY

8.8 HEATING PLATES

TOOLS: Phillips head screwdriver
Small putty knife

Note: Like the headlights on a car, if one heating plate burns out, the other will likely burn out soon. Therefore, it would be advisable to replace both plates at once.

WARNING:

Disconnect power from the wall outlet before attempting to service the furnace!

8.8.1 Follow steps 8.1.1 - 8.1.2 of CONTROL DRAWER REMOVAL.

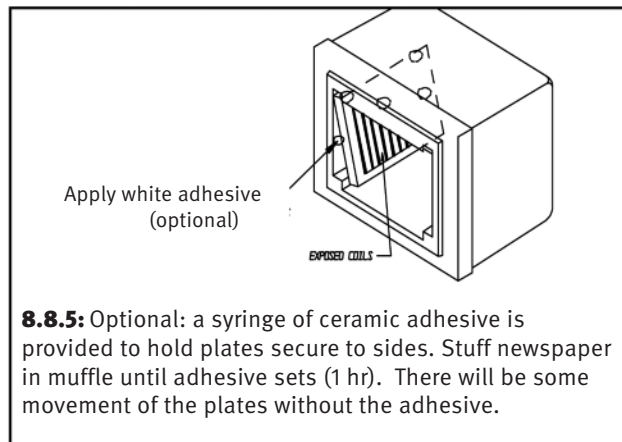
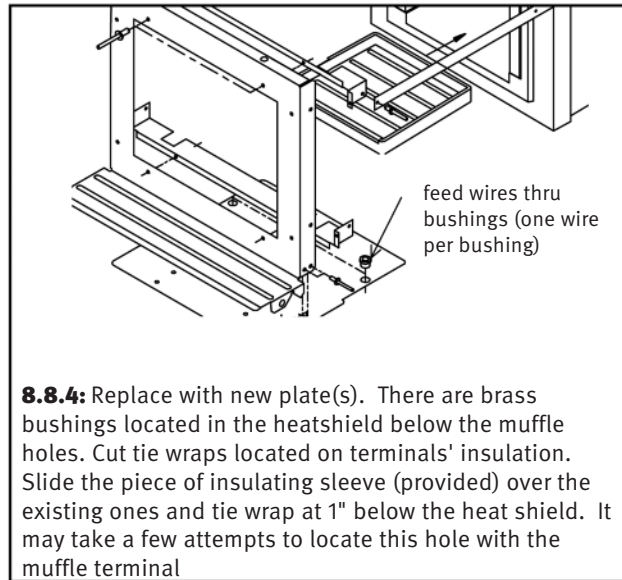
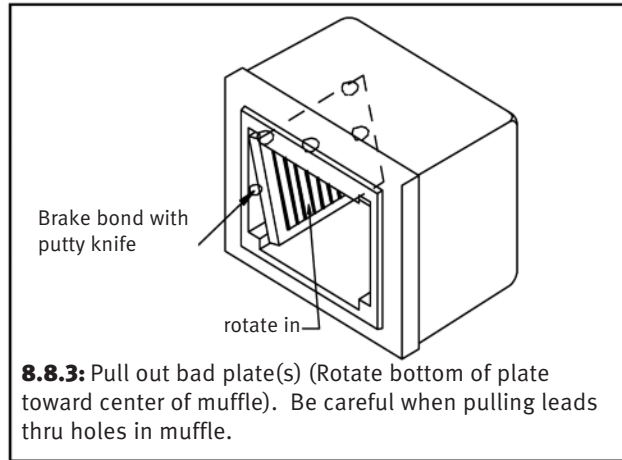
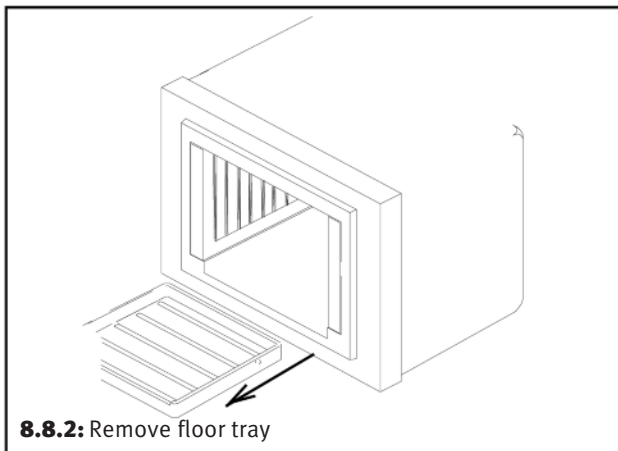
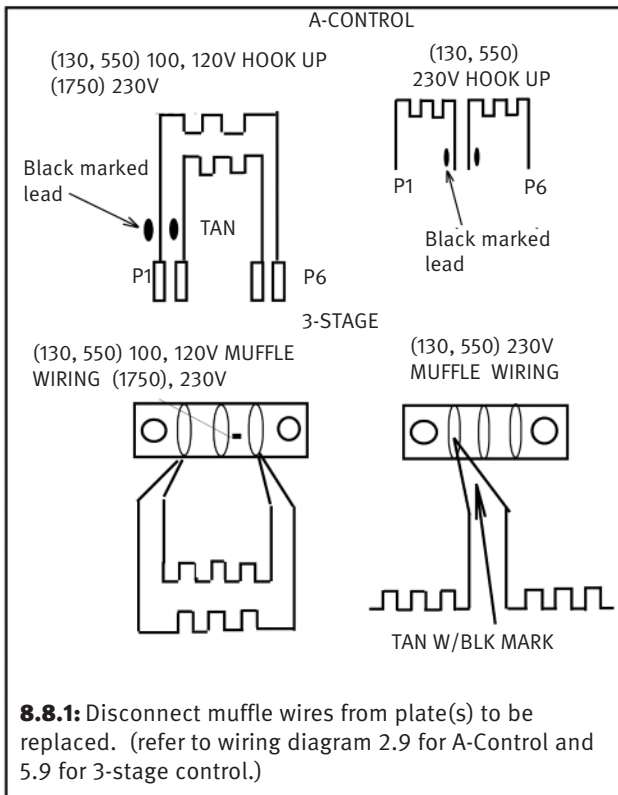

8.8.6: Connect muffle wires from plate(s) to control PCB. Refer to wiring diagram 2.8 for A-Control or 5.9 for 3 stage control. (See step 8.8.1)

8.8.7: Install floor tray

8.8.8: Install control drawer by reversing steps 8.1.1 - 8.8.5

SECTION 8 - DISASSEMBLY/REASSEMBLY

8.9 COMPLETE MUFFLE REPLACEMENT

TOOLS: Phillips head screwdriver; small flat head screwdriver; needle nose pliers

WARNING:

Disconnect power from the wall outlet before attempting to service the furnace!

8.9.1: Follow steps 8.1.1 - 8.1.2 of CONTROL DRAWER REMOVAL.

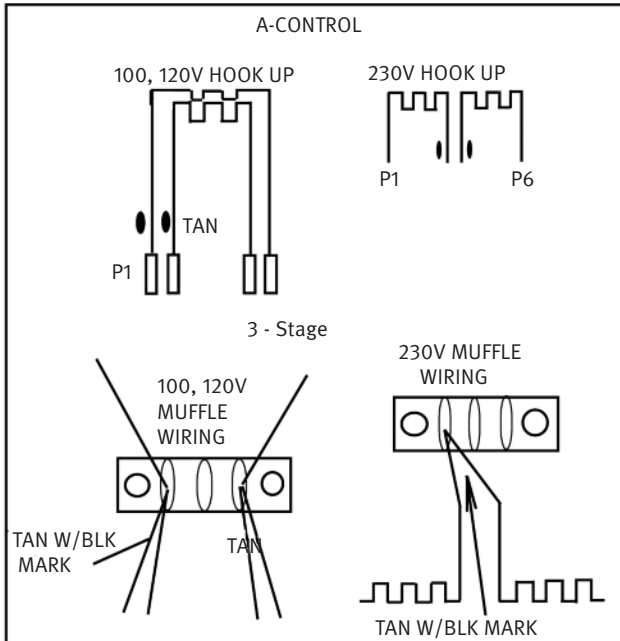

8.9.2: Disconnect muffle wires. (Refer to wiring diagram 2.8 for A-Control and 5.9 for 3 stage control.)

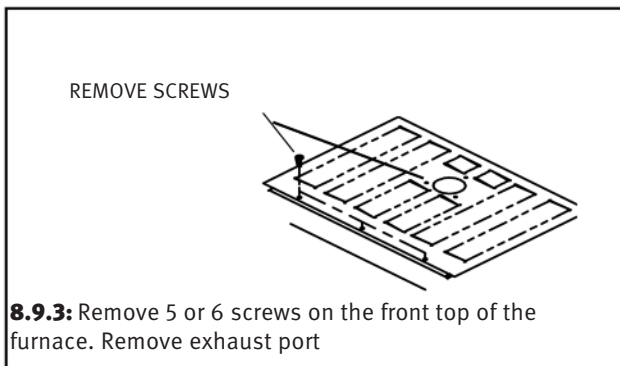

8.9.3: Remove 5 or 6 screws on the front top of the furnace. Remove exhaust port

8.9.4: Open door

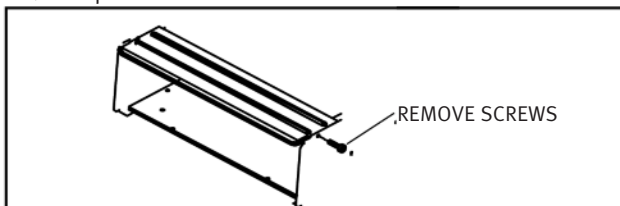

8.9.5: Remove two screws (one each side)

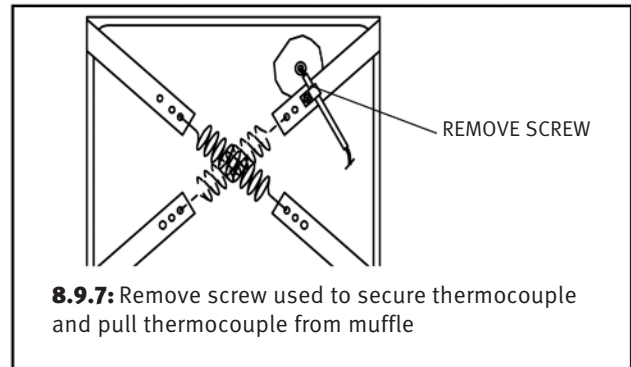
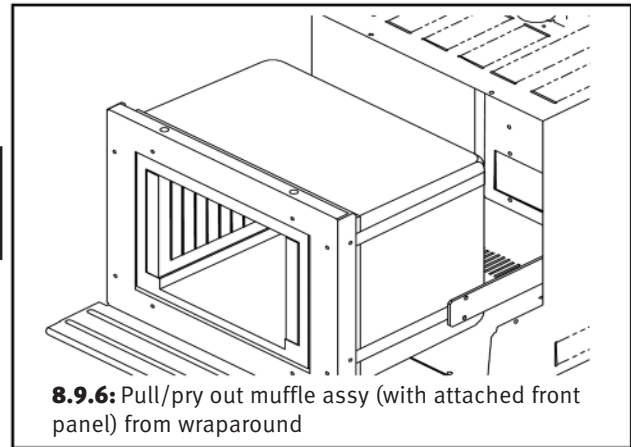

8.9.7: Remove screw used to secure thermocouple and pull thermocouple from muffle

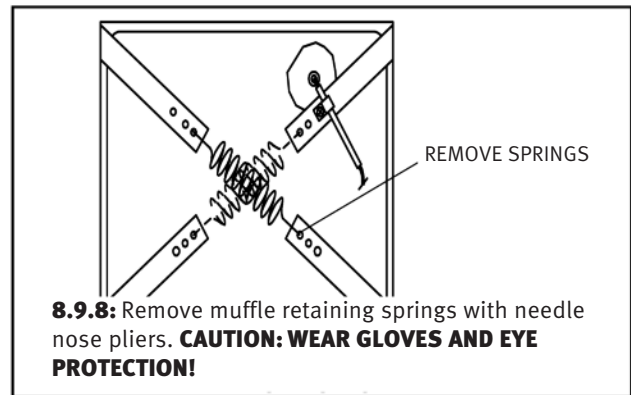

8.9.8: Remove muffle retaining springs with needle nose pliers. **CAUTION: WEAR GLOVES AND EYE PROTECTION!**

8.9.9: Remove muffle assy

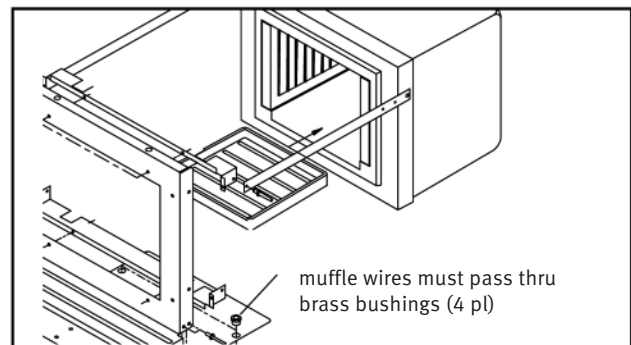

8.9.10: Replace with new muffle assy by reversing steps 8.9.1 - 8.9.9. Make sure that muffle wires pass thru brass bushings in heatshield

SECTION 8 - DISASSEMBLY/REASSEMBLY

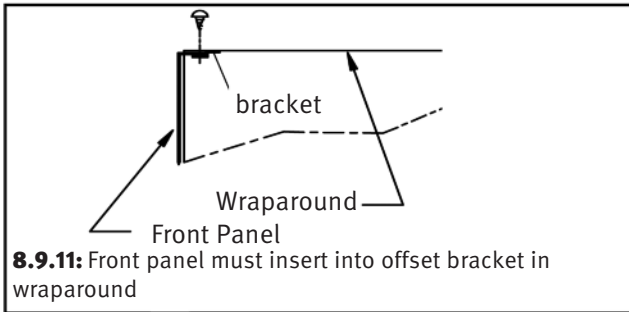

8.9.12: Check muffle resistance to verify wiring is correct before securing control drawer:

	100V	120V	200-240V
A-130, 3-130	11.5 ohms	11.5 ohms	32 ohms
A-550, 3-550	8 ohms	8 ohms	24 ohms
A-1750, 3-1750			12 ohms

8.10 THERMOCOUPLE (A-CONTROL)

TOOLS: bladed screwdriver phillips head screwdriver, 3/8" nutdriver, wrench, 1/4" nutdriver

WARNING:

Disconnect power from the wall outlet before attempting to service the furnace!

8.10.1: Follow steps 8.1.1 - 8.1.2 of control drawer removal

8.10.2: Follow steps 8.9.3 - 8.9.7 from previous page for muffle replacement for furnaces without a rear access panel. Note: All 1750 furnaces and all furnaces with S/N date codes after 9701 will have rear access panel so that muffle will not need to be removed to service thermocouple (see step 8.11.6 for details).

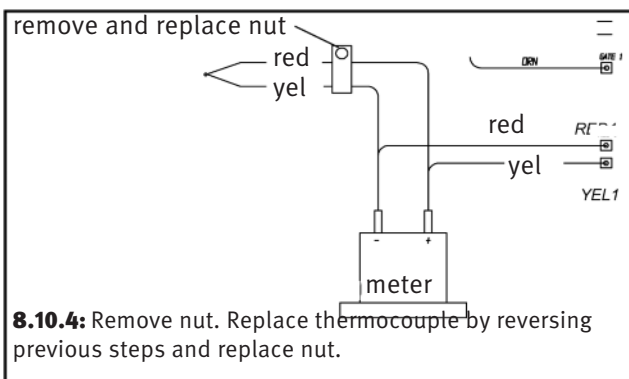
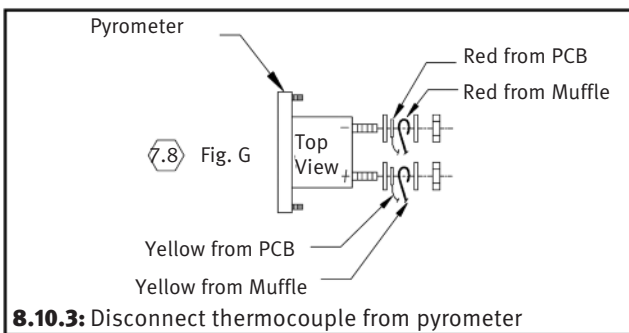

8.11 THERMOCOUPLE (3 STAGE CONTROL)

TOOLS: bladed screwdriver
phillips head screwdriver
1/4" nutdriver

WARNING:

Disconnect power from the wall outlet before attempting to service the furnace!

8.11.1: Follow steps 8.1.1 - 8.1.2 of control drawer removal

8.11.2: Follow steps 8.9.3 - 8.9.7 from previous page for muffle replacement for furnaces without a rear access panel. Note: All 1750 furnaces and all furnaces with S/N date codes after 9701 will have rear access panel so that muffle will not need to be removed to service thermocouple (see step 8.11.6 for details).

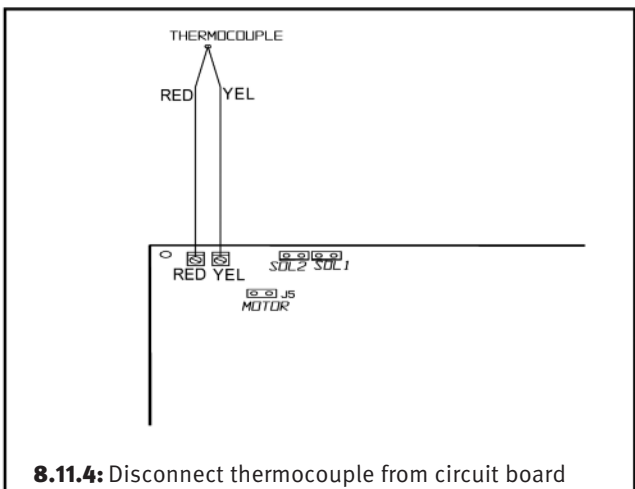
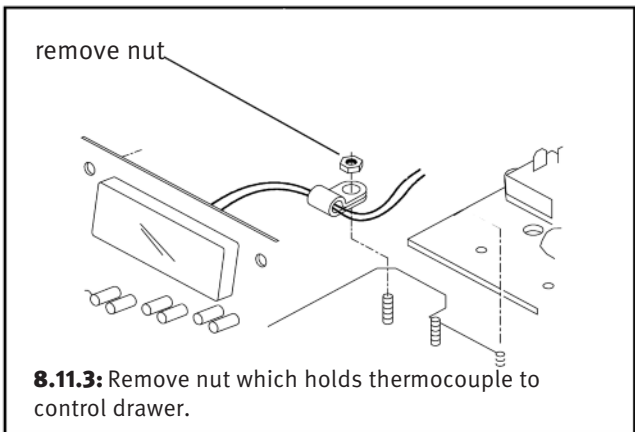

8.11.5: Replace with new thermocouple by reversing previous steps 8.11.1 thru 8.11.4

SECTION 8 - DISASSEMBLY/REASSEMBLY

8.12 COMPLETE MUFFLE REPLACEMENT

TOOLS: Phillips head screwdriver; bladed screw driver; needle nose pliers

8.12.1: Follow steps 8.1.1 - 8.1.2 of CONTROL DRAWER REMOVAL.

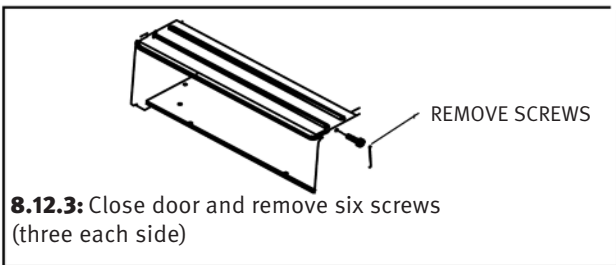
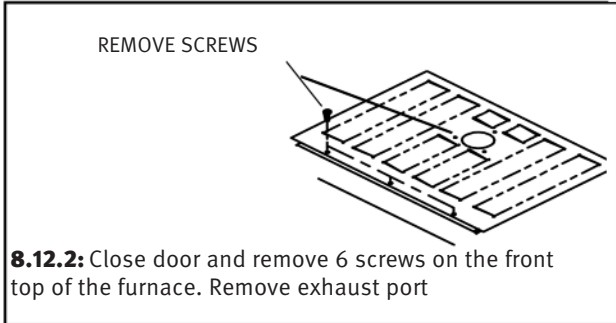

WARNING:

Disconnect power from the wall outlet before attempting to service the furnace!

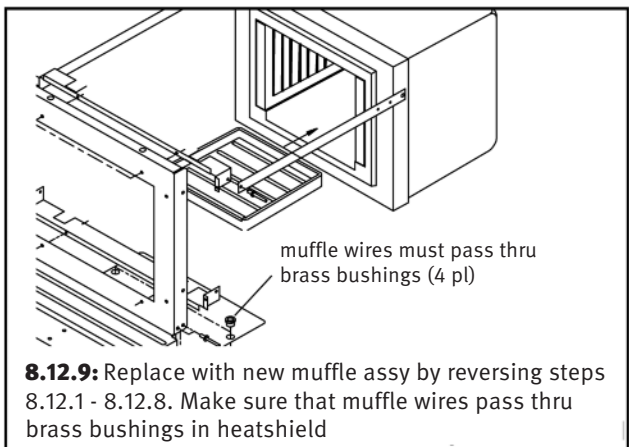
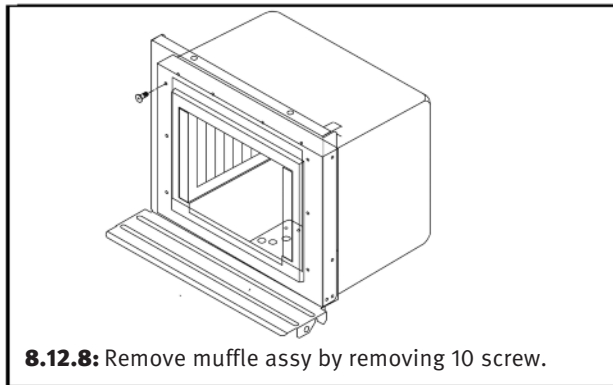
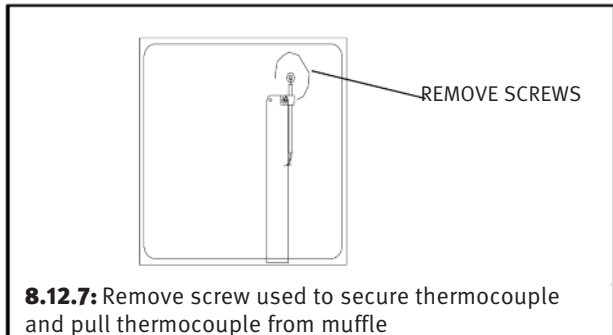
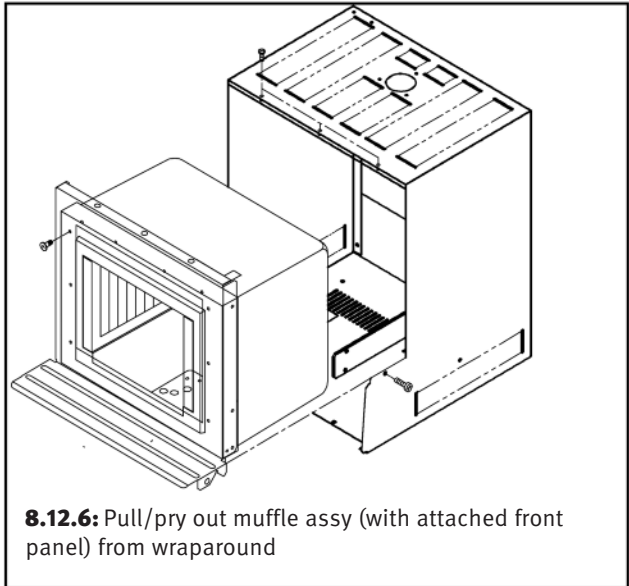
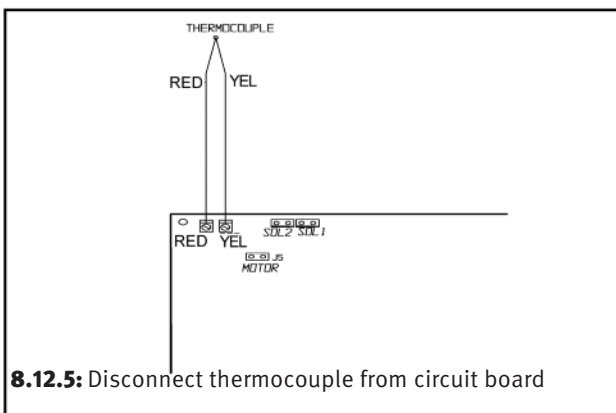
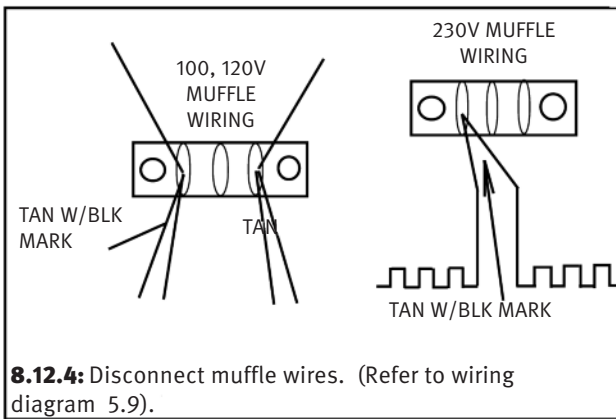

SECTION 8 - DISASSEMBLY/REASSEMBLY

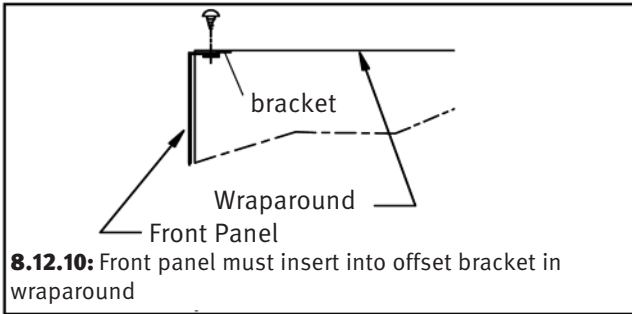

8.12.10: Front panel must insert into offset bracket in wraparound

8.12.11: Check muffle resistance to verify wiring is correct before securing control drawer:

	100v	120v	200-240v
3-550 PD	8 ohms	8 ohms	24 ohms

8.13 THERMOCOUPLE (3-550 PD)

TOOLS: bladed screwdriver
phillips head screwdriver
1/4" nutdriver

WARNING:

Disconnect power from the wall outlet before attempting to service the furnace!

8.13.1: Follow steps 8.1.1 - 8.1.2 of control drawer removal

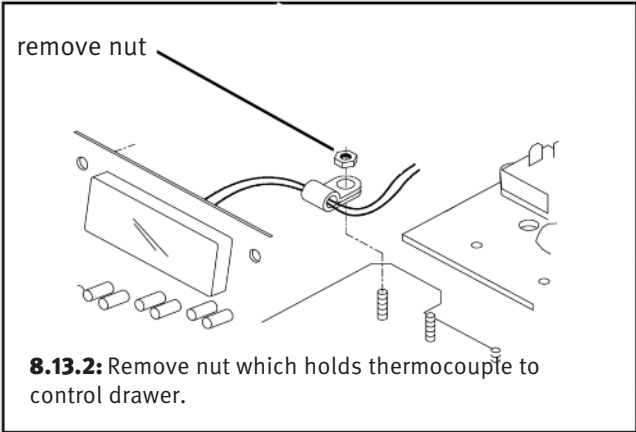

8.13.2: Remove nut which holds thermocouple to control drawer.

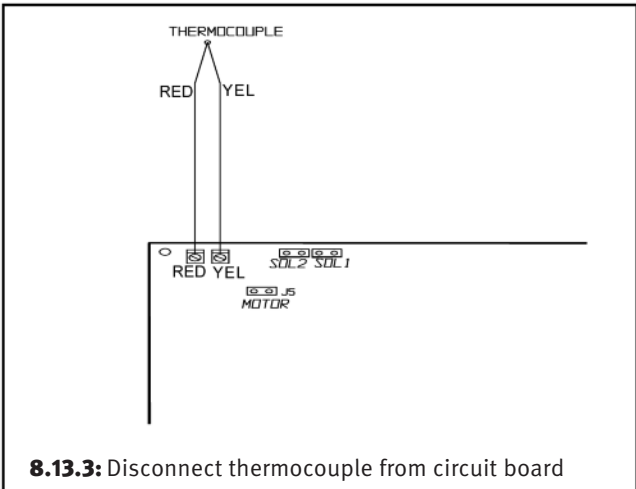

8.13.3: Disconnect thermocouple from circuit board

SECTION 8 - DISASSEMBLY/REASSEMBLY

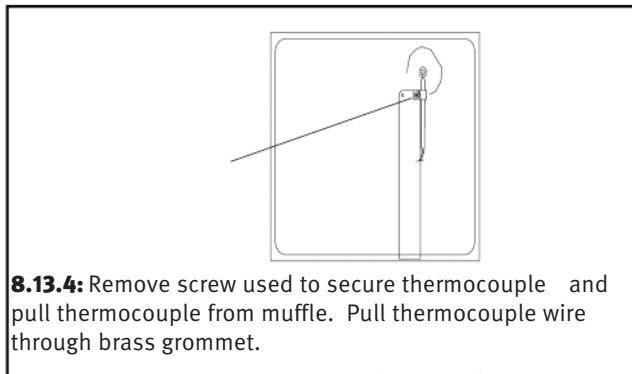
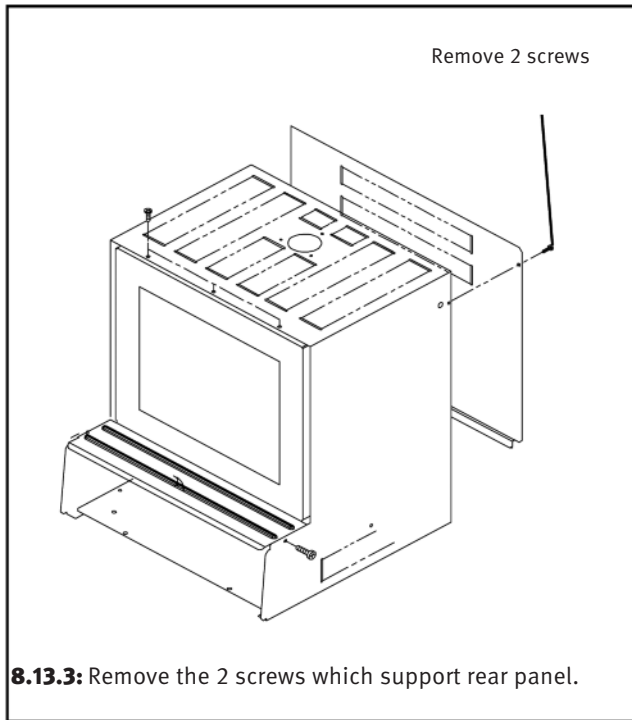

8.13.5: Replace with new thermocouple by reversing previous steps 8.11.1 thru 8.11.4

8.14 POWER SWITCH

TOOLS: Slotted screwdriver

8.14.1: Follow steps 8.1.1 through 8.1.2 of CONTROL DRAWER REMOVAL

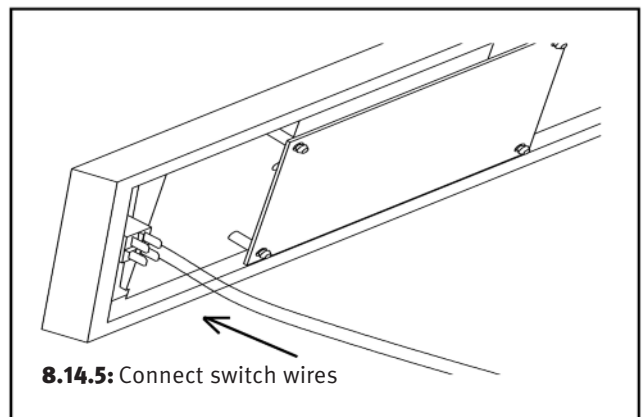
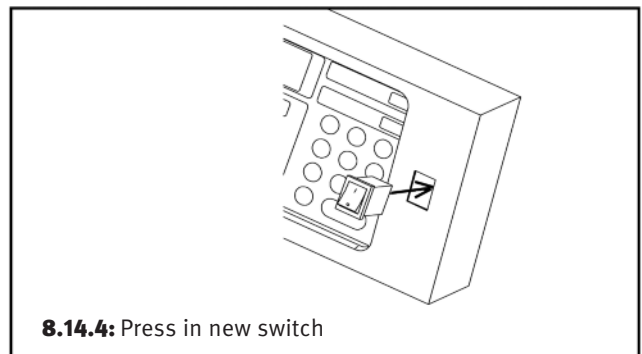
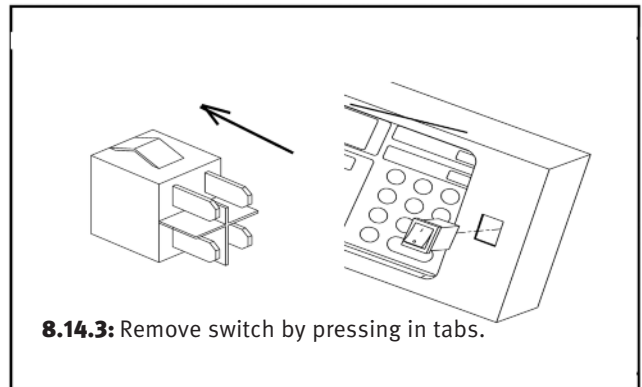
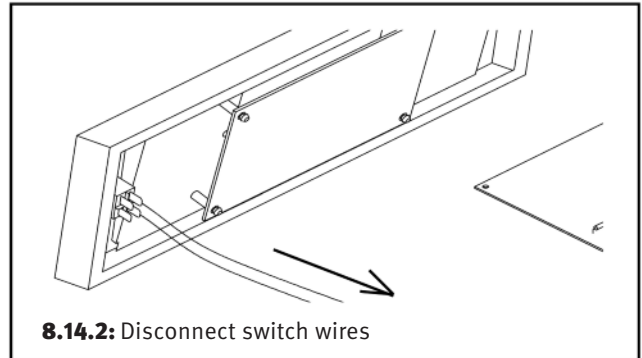

SECTION 8 - DISASSEMBLY/REASSEMBLY

8.15 POWER DOOR MOTOR REPLACEMENT

8.15.1: Slide control drawer forward using steps 8.1.1 and 8.1.2

8.15.2: Slide muffle assembly forward using steps 8.1.3, 8.9.4, 8.9.5 and 8.9.6 (approximately 5 inches).

8.15.3: Remove the 2 screws which support rear panel.

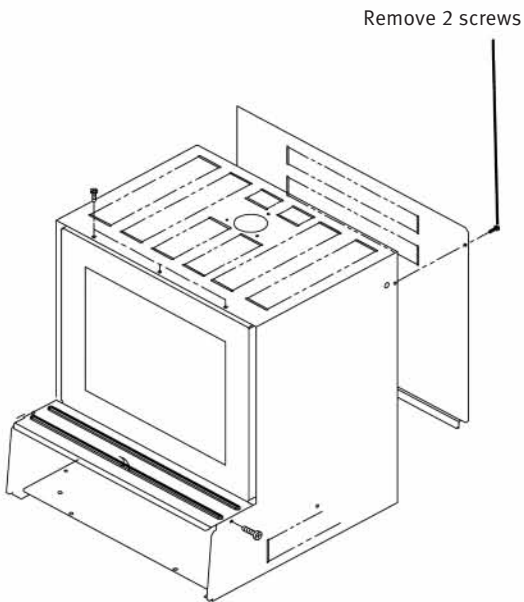

8.15.4: Remove the 2 screws to free motor linkage bracket from base.

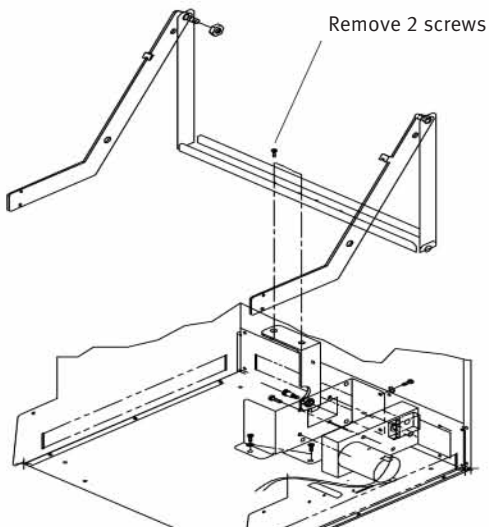

8.15.5: Disconnect wires (Female quick connect terminals) from motor.

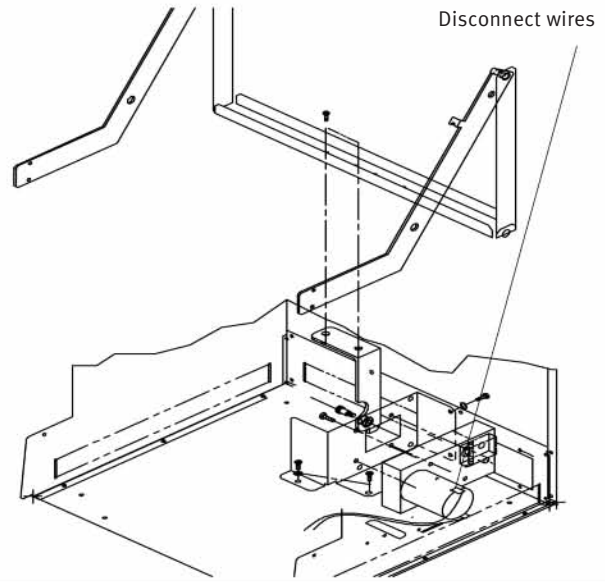

8.15.6: Remove (4) screws to free motor

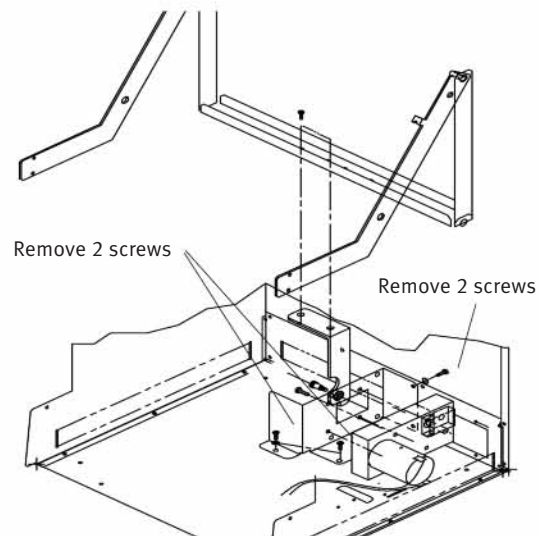

8.15.7: Remove (4) screws and shoulder bolt to free motor from motor bracket.

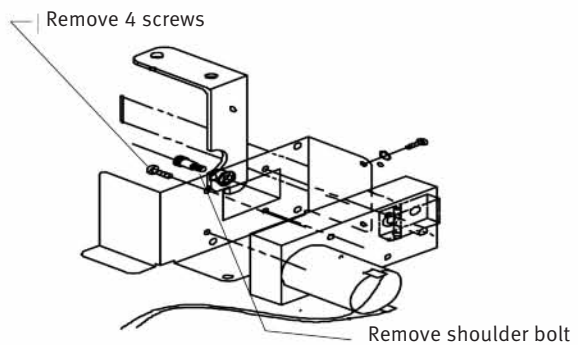

8.15.8: Replace with new motor by reversing previous steps 8.15.1 thru 8.15.7.

PRODUCT SERVICE:

Three methods of product service are available:

- Telephone assistance available at the number listed below.
- Return the unit for servicing using the instructions below.

BEFORE RETURNING THE UNIT:

- Call DENTSPLY for a PR (Product Return) number. This is used to track and identify your unit. Equipment received without this number may not be identifiable.
- If you do not have the original packaging, please request replacement packaging to ensure the unit is not damaged in shipment.
- Secure top section in down position using original rubber bands supplied with the original packaging.
- Equipment damaged in shipment as a result of improper packing may not be paid by the carrier.

DENTSPLY will not be responsible for damages resulting from improper packing.

Ship prepaid to:

DENTSPLY Ceramco

ATTN: Equipment Repair

PR Number _____

470 West College Ave.

York, PA 17404 USA

Phone: 800.835.6639 Option #1 (US Customers)

717.849.4502 (International Customers)

Fax: 909.795.5268

Email: equipmentrepair.ca@dentsply.com

DENTSPLY

CERAMCO®

Manufactured For:
DENTSPLY International Inc.
DENTSPLY Ceramco
570 West College Ave.
York, PA 17405-0872
1-800-243-1942
prosthetics.dentsply.com or dentsply.com

Distributed by:
DENTSPLY Canada
161 Vinyl Court
Woodbridge, Ontario
L4L 4A3
905-968-5374

Printed in U.S.A.
9363049 Rev. 12/11